

Guidelines for Measuring Audio Power Amplifier Performance

Richard Palmer
Audio Power Amplifiers

ABSTRACT

This application note provides guidelines for measuring the data sheet parameters of Texas Instruments audio power amplifiers (APAs) using prefabricated evaluation modules (EVMs). The primary equipment used for the measurements consists of the System Two™ audio measurement system by Audio Precision™, a digital multimeter (DMM), and a dc power supply.

Contents

1	Introduction.....	2
2	Basic Measurement System.....	3
3	Interfacing to the APA	5
	3.1 Differential Input and BTL Output (TPA731 and TPA2000D1)	5
	3.2 SE Input and SE Output (TPA0211 and TPA711)	6
	3.3 Other Configurations	7
	3.4 Class-D RC Low-Pass Filter.....	7
4	Total Harmonic Distortion Plus Noise (THD+N).....	9
	4.1 THD+N vs Output Power.....	10
	4.2 THD+N vs Frequency.....	11
	4.3 Maximum Output Power Bandwidth	11
	4.4 Maximum Input Voltage.....	11
5	Noise.....	12
	5.1 Integrated Noise vs Frequency.....	12
	5.2 Signal-to-Noise Ratio	13
6	Gain and Phase.....	13
7	Crosstalk	15
8	Supply Rejection.....	17
9	Power Measurements and Related Calculations	21
	9.1 Efficiency Measurements	21
	9.2 Power Dissipated vs Power to the Load	24
	9.3 Crest Factor and Output Power	25
10	Measurement Pitfalls	26
	10.1 Effects of Improper Interfacing and Grounding	26
	10.2 THD+N Measurements	27
	10.3 Noise Measurements	27
	10.4 Gain and Phase Measurements	28
	10.5 Crosstalk Measurements.....	28
	10.6 Supply Rejection Measurements.....	28
	10.7 Efficiency Measurements	28
11	References	28

Figures

Figure 1.	Audio Measurement Systems: (a) Class-AB APAs and (b) Filter-Free Class-D APAs	4
Figure 2.	Differential Input—BTL Output Measurement Circuit.....	5
Figure 3.	SE Input—SE Output Measurement Circuit.....	7
Figure 4.	Measurement Low-Pass Filter Derivation Circuit—Class-D APAs	8
Figure 5.	THD+N Measurement Circuit Using the AP-II Measurement System: Differential-BTL	10
Figure 6.	THD+N vs P_{OUT} for the TPA2001D1 and the TPA731	10
Figure 7.	THD+N vs Frequency for the TPA2001D1 and the TPA731	11
Figure 8.	Noise Measurement Circuit	12
Figure 9.	Measured Results of Noise Circuit	13
Figure 10.	Gain and Phase Measurement Circuit	14
Figure 11.	TPA731 Gain and Phase Measurements.....	14
Figure 12.	TPA2001D1 Gain and Phase Measurements	15
Figure 13.	Crosstalk Measurement Circuit.....	16
Figure 14.	Crosstalk Measurements.....	17
Figure 15.	PSRR and k_{SVR} Measurement Circuit	18
Figure 16.	k_{SVR} Filter Circuit	19
Figure 17.	k_{SVR} of the TPA2001D1 and TPA731	20
Figure 18.	Impact of C_{BYPASS} on k_{SVR} for the TPA711 Class-AB APA	20
Figure 19.	Efficiency Measurement Circuit for Class-AB and Class-D BTL APAs	22
Figure 20.	Efficiency Graphs of the TPA731 and TPA2001D1.....	24
Figure 21.	Graph of Power Dissipated vs Output Power.....	24
Figure 22.	Supply and Output Power vs CF for the TPA731 and TPA2001D1	26
Figure 23.	Effect of Generator Interface on APA Measurements, THD+N vs Power Shown.....	27

Tables

Table 1.	Recommended Minimum Wire Size for Power Cables	6
Table 2.	Typical RC Measurement Filter Values.....	9
Table 3.	Efficiency Data for the TPA731 and TPA2001D1.....	23
Table 4.	Power vs Crest Factor	25

1 Introduction

The primary goal of audio measurements is to determine the performance of a device in the audible spectrum, 20 Hz to 20 kHz. Although most people do not hear frequencies below 50 Hz or above 17 kHz, the broad spectrum is an industry standard that allows a more accurate comparison of devices. The performance can be quickly analyzed, and only a few basic pieces of equipment are required.

A method for measuring standard data sheet information for audio power amplifiers (APAs) is presented for several key parameters. These are:

- THD+N versus output power
- THD+N versus frequency
- Gain and phase versus frequency
- Integrated noise
- Signal-to-noise ratio
- Crosstalk versus frequency
- Power supply rejection ratio
- Supply ripple voltage rejection ratio
- Efficiency
- Power dissipated in the device

The measurements in this application note were made using TI Plug-N-Play APA evaluation modules (EVMs). The TPA2001D1 and TPA731 mono devices were used for most measurements. The TPA2001D2 and TPA0212 devices were used for the crosstalk measurements, which require a stereo device.

Note that the measurements are dependent upon the layout of the printed-circuit board (PCB), particularly with class-D APAs. The graphs in the data sheet reflect typical specifications and were measured on test boards specifically designed to allow accuracy and ease of measurement. The measurements in this application note, however, were taken using circuits on EVMs that reflect real-world layout constraints. The measurements of a particular audio circuit may vary from the typical specifications. A large variance is usually indicative of a PCB layout or measurement system issue.

2 Basic Measurement System

This application note focuses on methods that use the basic equipment listed below:

- Audio analyzer or spectrum analyzer
- Oscilloscope
- Signal generator
- Linear regulated power supply
- EVM or other complete audio circuit
- Digital multimeter (DMM)
- Twisted pair wires
- Power resistor(s)
- Filter components

Figure 1 shows the block diagrams of basic measurement systems for class-AB and class-D amplifiers. A sine wave is normally used as the input signal since it consists of the fundamental frequency only (no other harmonics are present). An analyzer is then connected to the APA output to measure the voltage output. The analyzer must be capable of measuring the entire audio bandwidth. A regulated dc power supply is used to reduce the noise and distortion injected into the APA through the power pins. A System Two audio measurement system (AP-II) (Reference 1) by Audio Precision includes the signal generator and analyzer in one package.

The generator output and amplifier input must be ac-coupled. However, the EVMs already have the ac-coupling capacitors, (C_{IN}), so no additional coupling is required. The generator output impedance should be low to avoid attenuating the test signal, and is important since the input resistance of APAs is not very high (about 10 k Ω). Conversely the analyzer-input impedance should be high. The output impedance, R_{OUT} , of the APA is normally in the hundreds of milli-ohms and can be ignored for all but the power-related calculations.

Figure 1(a) shows a class-AB amplifier system, which is relatively simple because these amplifiers are linear—their output signal is a linear representation of the input signal. They take analog signal input and produce analog signal output. These amplifier circuits can be directly connected to the AP-II or other analyzer input.

This is not true of the class-D amplifier system shown in Figure 1(b), which requires low pass filters in most cases in order to measure the audio output waveforms. This is because it takes an analog input signal and converts it into a pulse-width modulated (PWM) output signal that is not accurately processed by some analyzers.

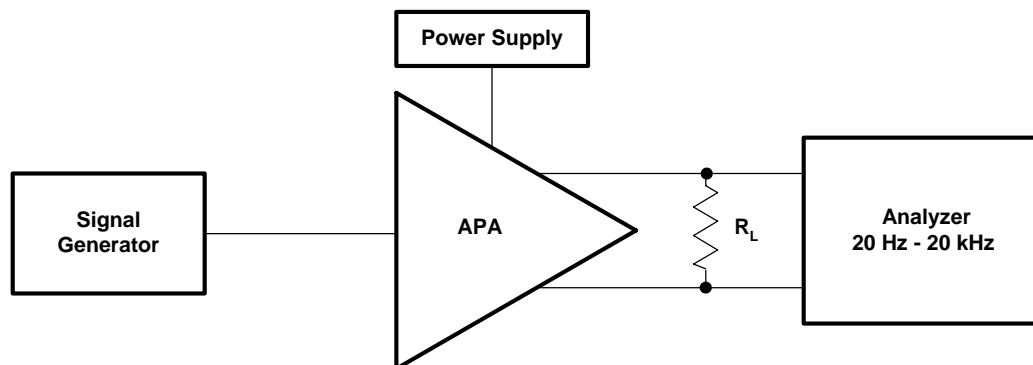

(a) Basic Class-AB Audio Measurement System

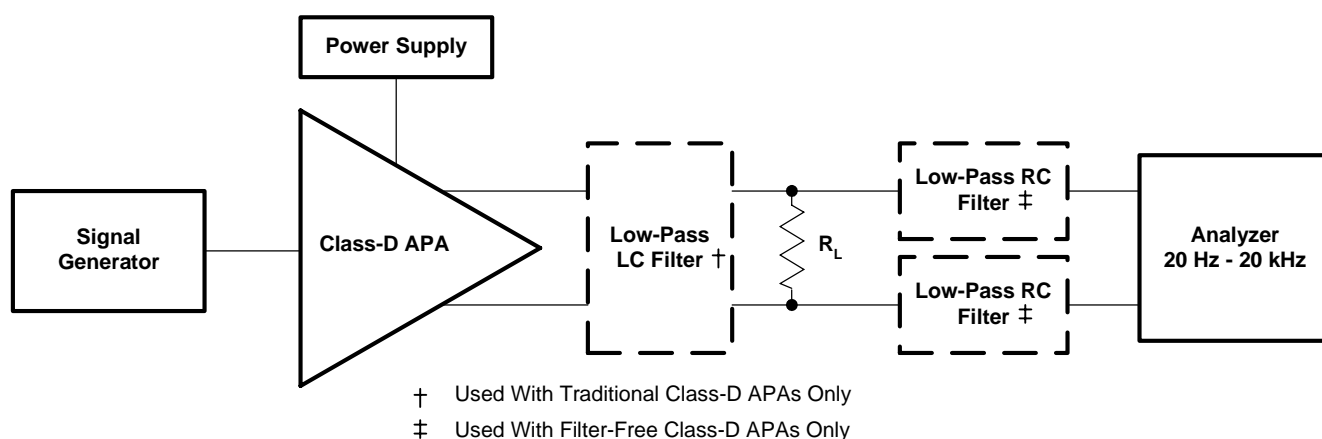

(b) Filter-Free and Traditional Class-D Audio Measurement System

Figure 1. Audio Measurement Systems: (a) Class-AB APAs and (b) Filter-Free Class-D APAs

Two types of class-D amplifiers exist: traditional class-D that requires a low-pass LC filter to produce an analog output, and TI's new filter-free class-D which does not require a low-pass output filter for normal operation because the speaker provides the inductance necessary to achieve high efficiency.

Two families of class-D APAs (TPA032D0x, TPA005Dxx) use the traditional modulation scheme that requires the LC filter for proper operation. The data sheets, EVM manuals, and application notes (References 2 and 3) provide more information about this filter.

The filter-free class-D APA families (TPA2000Dx and TPA2001Dx) use a modulation scheme that does not require an output filter for operation, but they do sometimes require an RC low-pass filter when making measurements. This is because some analyzer inputs cannot accurately process the rapidly changing square-wave output and therefore record an extremely high level of distortion. The RC low-pass measurement filter is used to remove the modulated waveforms so the analyzer can measure the output sine wave.

3 Interfacing to the APA

This section describes the important points to be considered when connecting the test equipment to the APA. The first two subsections describe the connections to differential and single-ended (SE) APA inputs and outputs. The last subsection discusses the RC low-pass filter design that is sometimes required for filter-free class-D measurements.

3.1 Differential Input and BTL Output (TPA731 and TPA2000D1)

All of the class-D APAs and many class-AB APAs have differential inputs and bridge-tied load (BTL) outputs. Differential inputs have two input pins per channel and amplify the difference in voltage between the pins. Differential inputs reduce the common-mode noise and distortion of the input circuit. BTL is a term commonly used in audio to describe differential outputs. BTL outputs have two output pins providing voltages that are 180 degrees out of phase. The load is connected between these pins. This has the added benefits of quadrupling the output power to the load and eliminating a dc blocking capacitor.

A block diagram of the measurement circuit is shown in Figure 2. The differential input is a balanced input, meaning the positive (+) and negative (-) pins will have the same impedance to ground. Similarly, the BTL output equates to a balanced output.

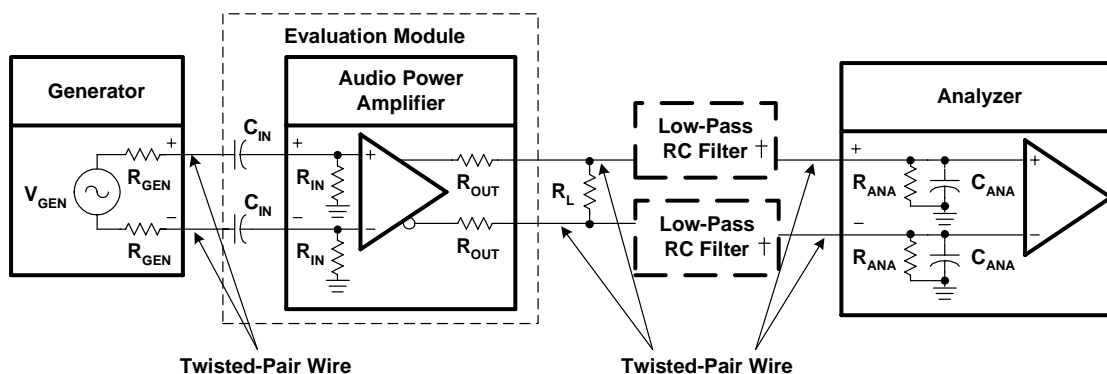

† The RC low-pass filter is required only for measuring the filter-free class-D audio power amplifiers.

Figure 2. Differential Input—BTL Output Measurement Circuit

The generator should have balanced outputs and the signal should be balanced for best results. An unbalanced output can be used, but it may create a ground loop that will affect the measurement accuracy. The analyzer must also have balanced inputs for the system to be fully balanced, thereby cancelling out any common mode noise in the circuit and providing the most accurate measurement.

The following general rules should be followed when connecting to APAs with differential inputs and BTL outputs:

- Use a balanced source to supply the input signal.
- Use an analyzer with balanced inputs.
- Use twisted-pair wire for all connections.

- Use shielding when the system environment is noisy.
- Ensure the cables from the power supply to the APA, and from the APA to the load, can handle the large currents (see Table 1 below).

Table 1 shows the recommended wire size for the power supply and load cables of the APA system. The real concern is the dc or ac power loss that occurs as the current flows through the cable. These recommendations are based on 12-inch long wire with a 20-kHz sine-wave signal at 25°C.

Table 1. Recommended Minimum Wire Size for Power Cables

$P_{OUT}(W)$	$R_L(\Omega)$	AWG Size	DC Power Loss (mW)	AC Power Loss (mW)
10	4	18	16	18
		22	40	42
2	4	18	3.2	3.7
		22	8.0	8.5
1	8	22	2.0	2.1
		28	8.0	8.1
< 0.75	8	22	1.5	1.6
		28	6.1	6.2

3.2 SE Input and SE Output (TPA0211 and TPA711)

The SE input and output configuration is used with class-AB amplifiers only. A block diagram of a fully SE measurement circuit is shown in Figure 3. Fully SE APAs are, in general, headphone or headset amplifiers, though the TPA0211 and TPA711 are APAs with SE capability. SE inputs normally have one input pin per channel. In some cases two pins are present; one is the signal and the other is ground. SE outputs have one pin driving a load through an output ac coupling capacitor and the other end of the load is tied to ground. SE inputs and outputs are considered to be unbalanced, meaning one end is tied to ground and the other to an amplifier input/output.

The generator should have unbalanced outputs, and the signal should be referenced to the generator ground for best results. Unbalanced or balanced outputs can be used when floating, but they may create a ground loop that will effect the measurement accuracy. The analyzer should have balanced inputs to cancel out any common-mode noise in the measurement.

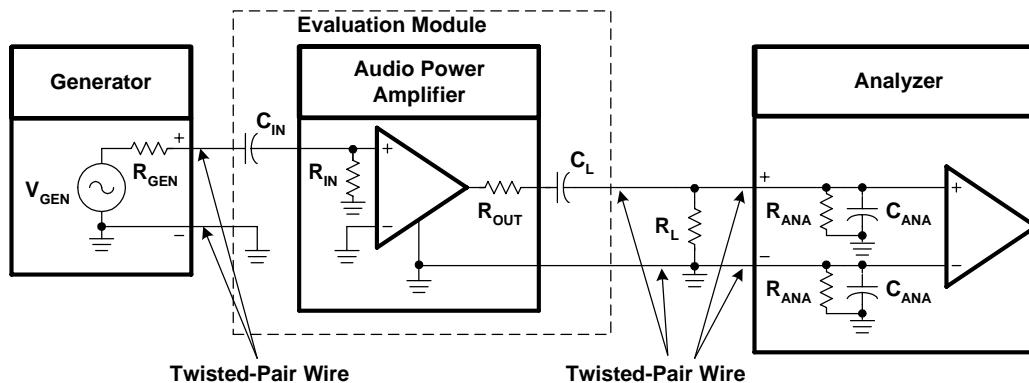

Figure 3. SE Input—SE Output Measurement Circuit

The following general rules should be followed when connecting to APAs with SE inputs and outputs:

- Use an unbalanced source to supply the input signal.
- Use an analyzer with balanced inputs.
- Use twisted pair wire for all connections.
- Use shielding when the system environment is noisy.
- Ensure the cables from the power supply to the APA, and from the APA to the load, can handle the large currents (see Table 1, Section 3.1)

3.3 Other Configurations

Some APAs are designed to operate in some combination of the two previously discussed configurations. For example, the TPA0312 is configured with differential inputs and SE outputs while the TPA711 is configured with SE inputs and BTL outputs. The TPA0212 can be operated with any combination of inputs and outputs. The relevant portions of Sections 3.1 and 3.2 are then used to configure the measurement system properly.

3.4 Class-D RC Low-Pass Filter

An RC filter is used to reduce the square-wave output when the analyzer inputs cannot process the pulse-width modulated class-D output waveform. This filter has little effect on the measurement accuracy because the cutoff frequency is set above the audio band. The high frequency of the square wave has negligible impact on measurement accuracy because it is well above the audible frequency range and the speaker cone cannot respond at such a fast rate. The RC filter is not required when an LC low-pass filter is used, such as with the class-D APAs that employ the traditional modulation scheme (TPA032D0x, TPA005Dxx).

The component values of the RC filter are selected using the equivalent output circuit as shown in Figure 4. R_L is the load impedance that the APA is driving for the test. The analyzer input impedance specifications should be available and substituted for R_{ANA} and C_{ANA} . The filter components, R_{FILT} and C_{FILT} , can then be derived for the system. The filter should be grounded to the APA near the output ground pins or at the power supply ground pin to minimize ground loops.

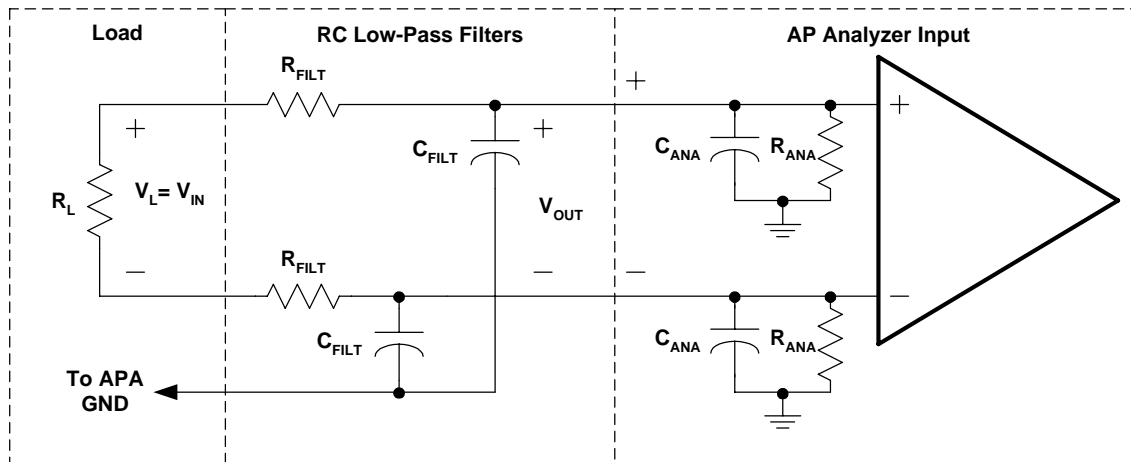

Figure 4. Measurement Low-Pass Filter Derivation Circuit—Class-D APAs

The transfer function for this circuit is shown in Equation (1) where $\omega_O = R_{EQ}C_{EQ}$, $R_{EQ} = R_{FILT} \parallel R_{ANA}$ and $C_{EQ} = (C_{FILT} + C_{ANA})$. The filter frequency should be set above f_{MAX} , the highest frequency of the measurement bandwidth, to avoid attenuating the audio signal. Equation (2) provides this cutoff frequency, f_C . The value of R_{FILT} must be chosen large enough to minimize current that is shunted from the load, yet small enough to minimize the attenuation of the analyzer-input voltage through the voltage divider formed by R_{FILT} and R_{ANA} . A rule of thumb is that R_{FILT} should be small ($\sim 100 \Omega$) for most measurements. This reduces the measurement error to less than 1% for $R_{ANA} \geq 10 \text{ k}\Omega$.

$$\left(\frac{V_{OUT}}{V_{IN}} \right) = \frac{\left(\frac{R_{ANA}}{R_{ANA} + R_{FILT}} \right)}{1 + j \left(\frac{\omega}{\omega_O} \right)} \quad (1)$$

$$f_C = \sqrt{2} \cdot f_{MAX} \quad (2)$$

An exception occurs with the efficiency measurements, where R_{FILT} must be increased by a factor of ten to reduce the current shunted through the filter. C_{FILT} must be decreased by a factor of ten to maintain the same cutoff frequency. See Table 2 for the recommended filter component values.

Once f_C is determined and R_{FILT} is selected, the filter capacitance is calculated using Equation (3). When the calculated value is not available, it is better to choose a smaller capacitance value to keep f_C above the minimum desired value calculated in Equation (2).

$$C_{\text{FILT}} = \frac{1}{2\pi \cdot f_C \cdot R_{\text{FILT}}} \quad (3)$$

Table 2 shows recommended values of R_{FILT} and C_{FILT} based on common component values. The value of f_C was originally calculated to be 28 kHz for an f_{MAX} of 20 kHz. C_{FILT} , however, was calculated to be 57 000 pF, but the nearest values of 56 000 pF and 51 000 pF were not available. A 47 000 pF capacitor was used instead, and f_C is 34 kHz, which is above the desired value of 28 kHz.

Table 2. Typical RC Measurement Filter Values

Measurement	R_{FILT}	C_{FILT}
Efficiency	1 000 Ω	5 600 pF
All other measurements	100 Ω	56 000 pF

4 Total Harmonic Distortion Plus Noise (THD+N)

The THD+N measurement combines the effects of noise, distortion, and other undesired signals into one measurement and relates it (usually as a percentage) to the fundamental frequency. Ideally, only the fundamental frequency of the sine-wave input is present at the output of the APA, which in practice is never the case. Nonlinearities in the APA, internal and external noise sources, and layout or grounding issues are some of the contributors that distort the original input signal.

THD+N requires measuring the value of everything that remains, which includes harmonics and noise, after the fundamental frequency has been filtered. This value is then divided by the fundamental frequency and expressed as a percentage. The bandwidth is often limited to record only the portion of the noise in the audible spectrum. The signal generator, audio analyzer, and filters should have a noise floor and distortion that is at least 10 dB lower than the APA distortion in order to achieve an accurate measurement (Reference 4).

Figure 5 shows an Audio Precision II (AP-II) system setup for measuring the THD+N of differential-BTL APAs. The bandwidth is usually limited with filters in the analyzer to reduce the out-of-band noise; however, this also reduces relevant harmonics of the higher frequency signals. A filter cutoff frequency of 30 kHz is used for class-AB and class-D APAs to allow measurement of the third harmonic for a 10 kHz signal. The narrow bandwidth attenuates the distortion at higher frequencies, but these harmonics are beyond the audible threshold of the human ear and are not a factor.

Three measurements that express THD+N in some manner in the data sheets are THD+N versus output power, THD+N versus frequency, and the maximum output power bandwidth, covered respectively in the following Sections 4.1 through 4.3. Section 4.4 provides a means to calculate and measure the maximum input voltage for an APA. These measurements vary with C_{BYPASS} for devices that have a BYPASS pin, with THD+N increasing as C_{BYPASS} decreases.

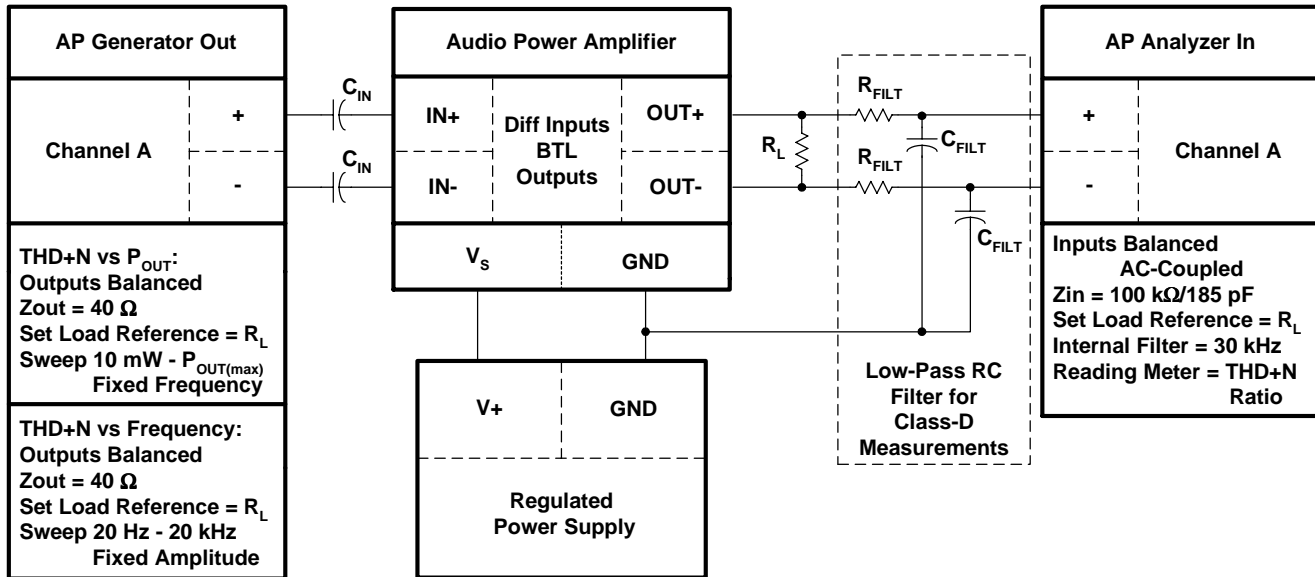

Figure 5. THD+N Measurement Circuit Using the AP-II Measurement System: Differential-BTL

4.1 THD+N vs Output Power

A graph of THD+N versus output power is shown in Figure 6. The signal generator sweeps the input voltage from low to high amplitude at a fixed frequency. The output power is calculated for a given load impedance that is entered into the audio analyzer software. At each voltage step the fundamental frequency is measured first, then filtered out and the amplitude of all the remaining harmonics is measured. This value is then divided by the amplitude of the fundamental frequency and graphed as a percentage of the fundamental.

The higher distortion at low values of P_{OUT} is due to the decrease in signal-to-noise ratio as the harmonics decrease in amplitude below the noise floor (Reference 4). The sudden increase at the upper level of P_{OUT} is due to clipping of the output signal.

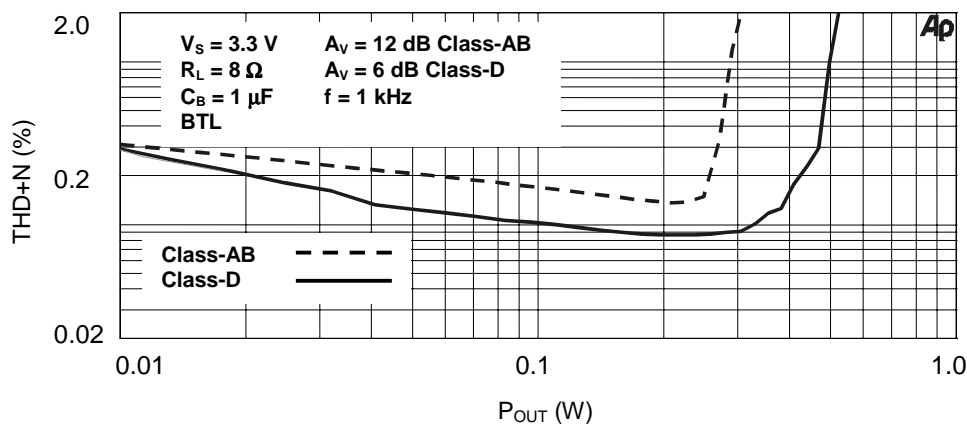

Figure 6. THD+N vs P_{OUT} for the TPA2001D1 and the TPA731

4.2 THD+N vs Frequency

A graph of THD+N versus frequency is shown in Figure 7. The signal generator sweeps the frequency from 20 kHz to 20 Hz at a fixed voltage. The harmonics and noise of the APA output are measured at specified frequency steps. Each step is divided by the amplitude of the fundamental frequency and graphed as a percentage of the fundamental. This graph provides a check when compared to the THD+N versus power since they should match at one specific frequency and power.

The increased THD+N at low frequencies is primarily due to the $1/f$ noise. The high frequency THD+N increase is due to device nonlinearities, primarily crossover distortion, and is expected because the APA open loop gain decreases with frequency. The audio quality is unaffected because the harmonics are above the audible threshold of the human ear (Reference 5). The rolloff at high frequencies is due to the band-limiting filter in the analyzer, which attenuates the upper harmonics above 30 kHz. Setting the filter frequency higher reduces the accuracy of the measurement with class-D APAs, and will have little or no impact on class-AB APAs. The class-AB graph continues in a relatively straight line if there is no filter present. The class-D rolls off more than class-AB because of the RC measurement filter, which adds another pole at 30 kHz.

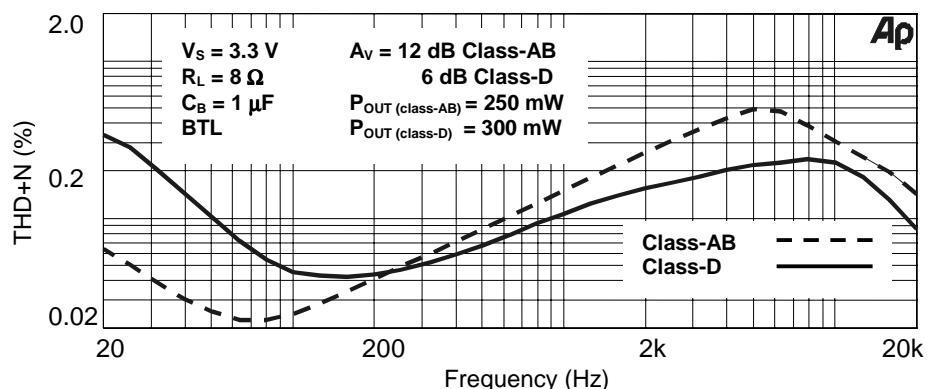

Figure 7. THD+N vs Frequency for the TPA2001D1 and the TPA731

4.3 Maximum Output Power Bandwidth

The maximum output power bandwidth is a THD+N versus frequency measurement. The APA is driven at the maximum output power into the load and the frequency is swept from 20 Hz to 20 kHz. The maximum power bandwidth is then specified as the frequency range over which the THD+N remains below a specified percentage, which is normally one percent.

4.4 Maximum Input Voltage

The maximum input voltage required for producing maximum output power can be found by increasing the input until the output clips, then reducing it until it is just below clipping. Another method is to calculate the maximum peak-to-peak input voltage using the maximum-rated RMS output power from the data sheet or back-calculate it from the THD+N versus power measurement at the maximum desired value of distortion. Equation (4) provides the maximum peak-to-peak input voltage, where $P_{OUT(max)}$ is the maximum rated RMS output power, R_L is the load resistance, and A_V is the voltage gain of the APA, measured in V/V.

$$V_{IN(P-P)} = \frac{2 \cdot \sqrt{2 \cdot P_{OUT(max)} \cdot R_L}}{A_V} \quad (4)$$

5 Noise

Two types of measurements fall under the noise category, integrated noise over the audio band and signal-to-noise ratio (SNR) of the output signal.

5.1 Integrated Noise vs Frequency

The noise measurement circuit is shown in Figure 8 for an APA with differential inputs and BTL outputs. A graph depicting the output noise voltage of the TPA2001D1 and the TPA731 is shown in Figure 9. All of the inputs of the APA should be ac-coupled to ground through the input resistor, whether internal or external, to reduce noise pickup and accurately simulate the system. A graph of THD+N versus P_{OUT} is shown in Figure 6. The AP generator outputs are not used in this measurement and should be turned off.

The analyzer should be set to measure amplitude and should be limited to measure the noise in the audio spectrum only. The bandwidth is limited to the range of 22 Hz – 22 kHz with filters in the analyzer. The data field of the sweep panel is set to measure the analyzer amplitude (Anlr Ampl) and the source field is set to sweep the generator frequency (Gen Freq) which is swept from 20 kHz to 20 Hz. The output should be set to V RMS and may be divided by the gain to get the input referred noise voltage, though the data sheets normally specify the output noise voltage in μV RMS.

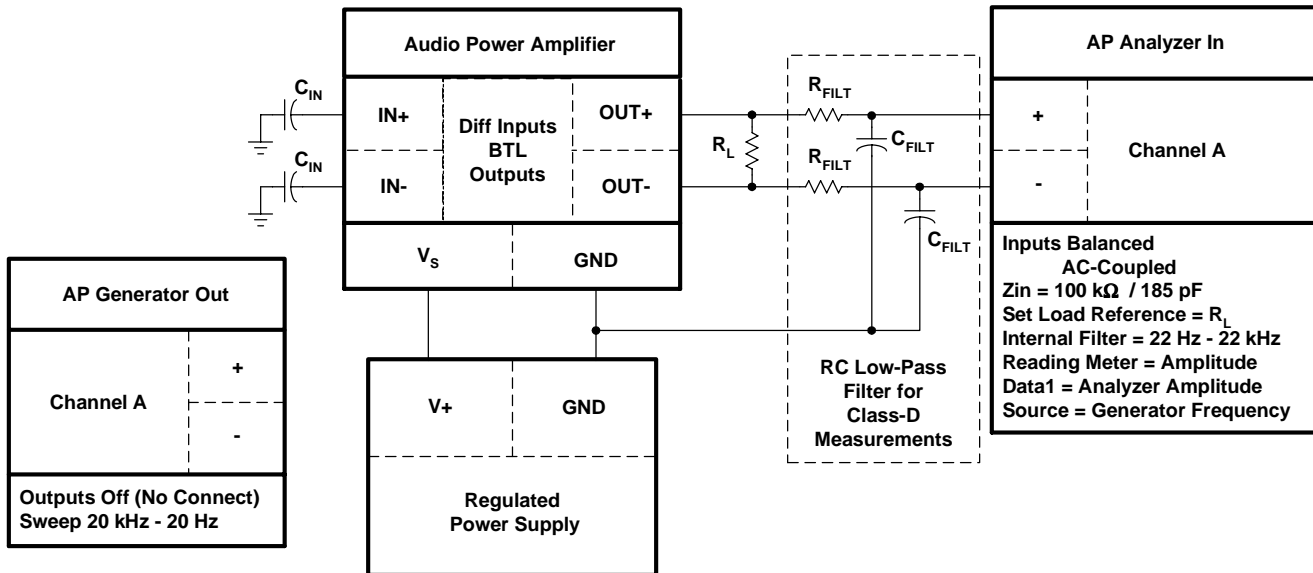

Figure 8. Noise Measurement Circuit

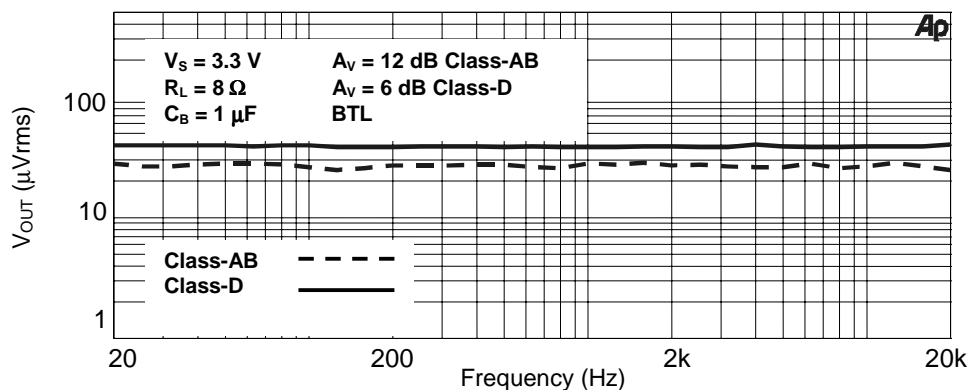

Figure 9. Measured Results of Noise Circuit

5.2 Signal-to-Noise Ratio

The signal-to-noise ratio (SNR) is the measure of the maximum output voltage compared to the integrated noise floor over the audio bandwidth, expressed in dB. It is normally specified at a precise power in the data sheet tables. The integrated noise floor is measured using the technique described in Section 5.1. The distortion of the output waveform is then measured at 1 kHz by sweeping the input voltage. The AP setup is the same as per the THD+N versus power measurements, with V_{OUT} , in V RMS, graphed on the x-axis rather than P_{OUT} . The point at which the output voltage begins to clip (the THD+N increases sharply) is considered to be the maximum output voltage.

The SNR is calculated using Equation (5). The noise and signal data can also be expressed in decibel-volts (dBV), which is the dB ratio of the measured voltage to 1 V, and Equation (5) then simplifies to Equation (6).

$$\text{SNR} = 20 \cdot \log \left(\frac{V_{OUT}^{\text{RMS}}}{V_{NOISE}^{\text{RMS}}} \right) \quad (5)$$

$$\text{SNR} = \text{dBV}_{OUT} - \text{dBV}_{NOISE} \quad (6)$$

Any unused input should be ac-grounded. The measurement bandwidth should be limited to provide an accurate measurement of the integrated noise floor.

6 Gain and Phase

The AP measurement circuit is shown in Figure 10 for a mono-channel, BTL-output APA. Measurements for the TPA731 and TPA2001D1 are shown in Figures 11 and 12. The gain and phase can also be measured at multiple points with an oscilloscope using Equation (7) for the gain and Equation (8) for the phase, where Δt is the time delay between the input and output voltages and f is the frequency of the input signal. The data is then plotted versus frequency.

$$A_V (\text{dB}) = 20 \cdot \log \left(\frac{V_{OUT}}{V_{IN}} \right) \quad (7)$$

$$\theta = \Delta t \cdot f \cdot 360^\circ \quad (8)$$

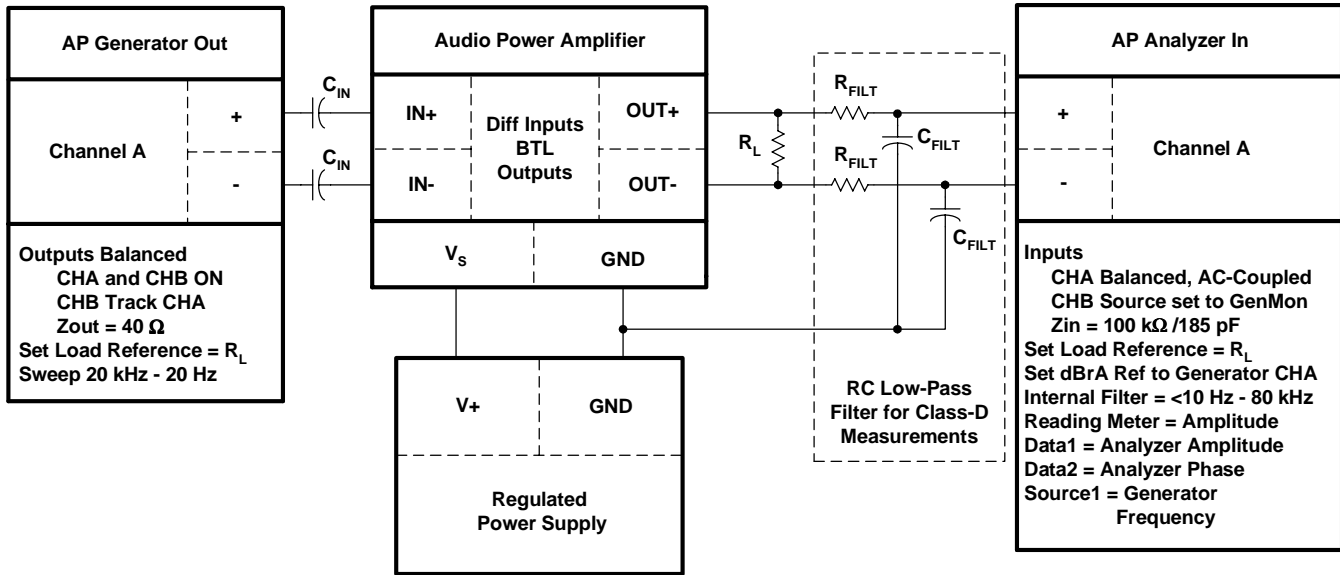

Figure 10. Gain and Phase Measurement Circuit

Figure 10 is the AP-II setup for measuring a single channel of the APA. Both channels must be turned on at the generator panel in the software and CHB set to track CHA. The analyzer CHB is set to GenMon (generator monitor), which means it takes its input directly from the generator output of the selected channel internal to the AP-II and uses it as the input phase reference for the analyzer measurement. The reference dBrA value should be set equal to the channel being swept, which in this case is CHA. This sets the input voltage of channel A as the reference for the gain measurement. It may be necessary to subtract 180° from the phase measurement to get the actual phase value.

The APA input ac-coupling capacitors produce the phase shift and attenuation at low frequencies. The class-D RC filter introduces some attenuation and phase shift at the measurement endpoints as seen in Figure 12. The AP analyzer band-pass filters should be set <10Hz and ≥ 30 kHz to minimize their impact on the measurement.

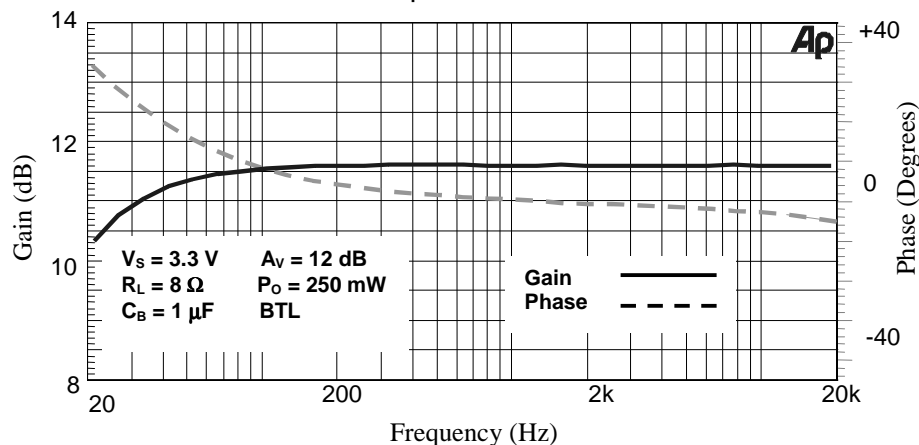

Figure 11. TPA731 Gain and Phase Measurements

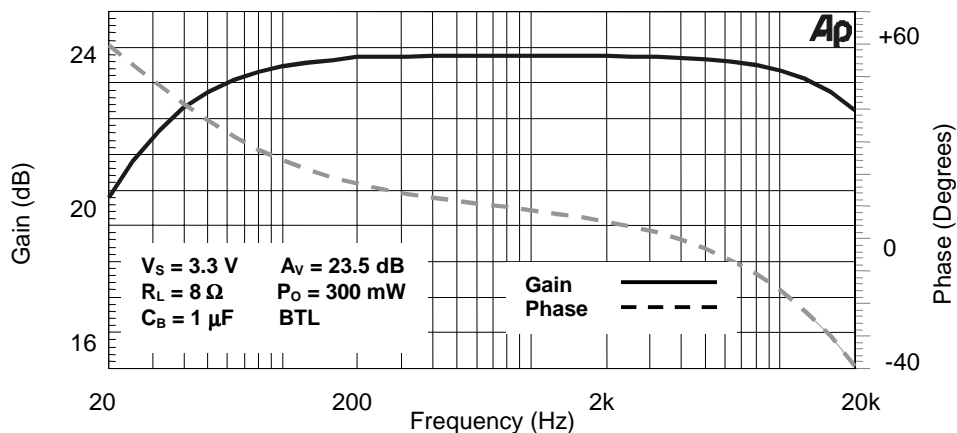

Figure 12. TPA2001D1 Gain and Phase Measurements

7 Crosstalk

Crosstalk is the measure of the signal coupling between channels of a stereo device. The crosstalk measurement circuit is shown in Figure 13 for an APA with differential inputs and BTL outputs. This particular circuit is set up to measure right-to-left (R-L) channel crosstalk, or the amount of signal that couples from the right channel (CHA) into the left channel (CHB). An input signal is fed into the right channel and the outputs of both channels are measured and compared as shown in Equation (9). The input voltage is fixed and is swept from 20 kHz to 20 Hz. The setup is inverted to graph the L-R channel crosstalk and the terms in parentheses in Equation (9) are inverted.

$$\text{Crosstalk} = 20 \cdot \log \left(\frac{V_{\text{CHB}}^{\text{OUT}}}{V_{\text{CHA}}^{\text{OUT}}} \right) \quad (9)$$

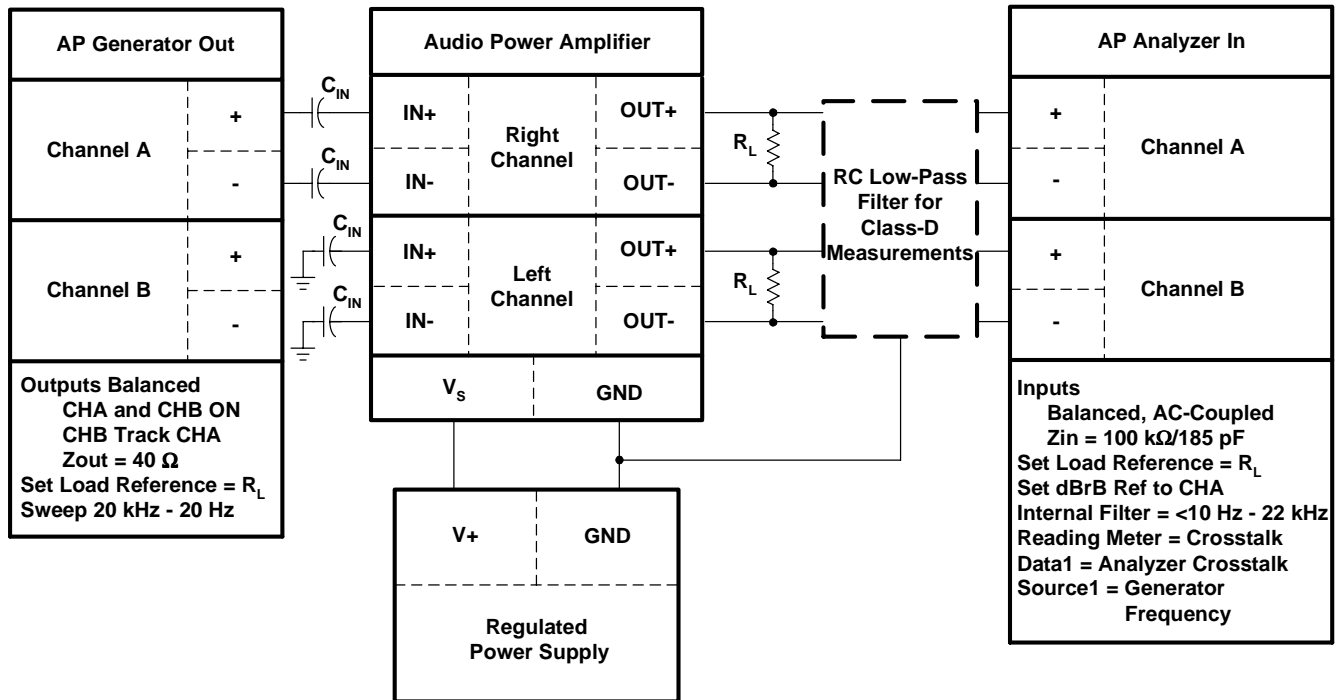

Figure 13. Crosstalk Measurement Circuit

Both channels must be turned on at the generator panel in the software and CHB set to track CHA. The input is swept over the audio frequency range at constant amplitude. The input voltage should be set to the highest amplitude that does not cause the output voltage to clip. Equation (10) is used for deriving the maximum peak-to-peak input voltage, where $P_{OUT(max)}$ is the maximum rated RMS output power, R_L is the load resistance, and A_V is the voltage gain of the APA. The internal filter can be set to 30 kHz or greater to limit noise, but is otherwise not required. The output cables of each channel should be separated to minimize capacitive coupling between them.

$$V_{IN(P-P)} = \frac{2 \cdot \sqrt{2 \cdot P_{OUT(max)} \cdot R_L}}{A_V} \quad (10)$$

Connections for the measurements of SE devices are made in the same way as for BTL devices, but with one end of R_L tied to ground and a capacitor inserted between R_L and $OUT+$ of the APA. The measurement is taken across R_L only, and not across R_L and the capacitor.

A graph of the R-L crosstalk is shown in Figure 14. When both R-L and L-R crosstalk measurements are shown, the graphs of both channels of the device are different. This is due to impedance mismatch between the channels, which is caused by nonsymmetrical layout of the IC.

The crosstalk was measured for the TPA0212 class-AB APA and TPA2001D2 class-D APA. The values are in close agreement with the data sheet graphs. The class-D crosstalk improves as the supply voltage is decreased because the radiation from the traces is decreased. Class-AB amplifiers are relatively unaffected by changes in supply voltage. The crosstalk increases in all amplifiers as the signal gain increases.

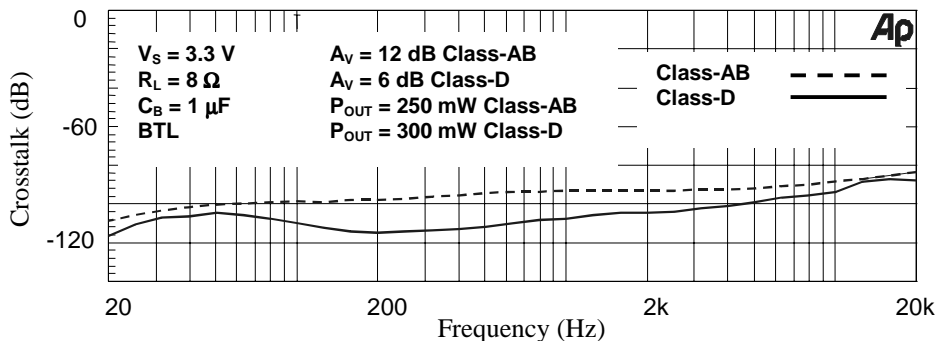

Figure 14. Crosstalk Measurements

8 Supply Rejection

Two types of supply rejection specifications exist: power supply rejection ratio (PSRR) and supply ripple rejection ratio (k_{SVR}). PSRR is a dc specification measuring the change in output offset voltage for a change in supply voltage. k_{SVR} is an ac specification measuring the ability of the APA to reject ac-ripple voltage on the power supply bus. All power supply decoupling capacitors are removed from class-AB circuits, and class-D measurements have a small 0.1 μ F decoupling capacitor placed close to the APA power pins to provide reverse path for recovery switching currents. It is recommended that the designer use equal decoupling capacitance values when comparing devices from different manufacturers to get a valid comparison of the performance, because a higher capacitance equates to a better k_{SVR} .

PSRR is the ratio of the change in the output voltage, $V_{OUT(dc)}$ for a change in the power supply voltage, V_S , expressed in dB as shown in Equation (11). For example, the output voltage of an audio power amplifier that has a PSRR of -70 dB would change by 31.6 μ V if the supply voltage changed by 0.1V.

$$PSRR = 20 \log \left(\frac{\Delta V_{OUT(dc)}}{\Delta V_S} \right) \quad (11)$$

k_{SVR} is the ratio of the output ripple voltage, $V_{OUT(ac)}$, to the supply ripple voltage, expressed in dB as shown in Equation (12). This parameter is normally listed as a typical value in the data sheet tables at a specified frequency and temperature of 1 kHz and 25°C, respectively. A graph is provided in the data sheet of the typical values of k_{SVR} over the audio bandwidth, because it is a frequency-dependent parameter.

$$k_{SVR} = 20 \log \left(\frac{V_{OUT(ac)}}{V_S} \right) \quad (12)$$

The PSRR and k_{SVR} measurement circuit is shown in Figure 15. The PSRR measurement requires only the two DMMs; therefore R_{SVR} , C_{SVR} , the generator and analyzer, and the RC measurement filter are not needed. The power supply voltage, V_S , is initially set, then read from the meter on the power supply. When the power supply meter does not have the desired resolution, DMM1 is used to measure V_S . DMM2 then measures V_{OUT} across the load. V_S is then stepped up or down by a specific amount and the corresponding value of V_{OUT} is measured.

The differences of the two measurements are then substituted into Equation (11) and the PSRR is calculated for that specific change in supply voltage. PSRR is specified as a typical value that is valid for a given supply voltage range at 25°C. All APA inputs are ac-coupled to ground.

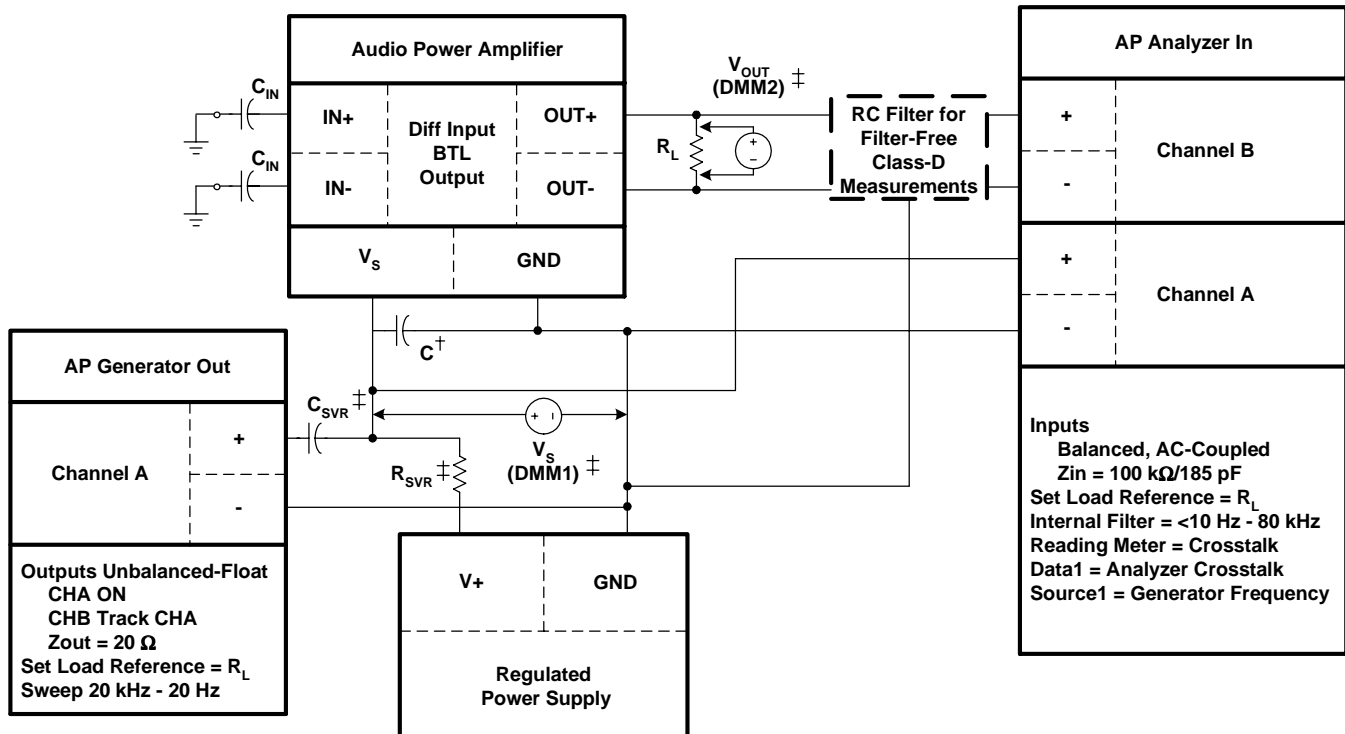

† The 0.1 μF capacitor, C, is required for class-D operation.

‡ The PSRR measurement uses the DMMs only because it is a dc value. k_{SVR} measurements use either the analyzer, oscilloscope or DMMs because it is an ac value. R_{SVR} and C_{SVR} are used for k_{SVR} measurements only.

Figure 15. PSRR and k_{SVR} Measurement Circuit

The k_{SVR} measurement requires the generator, analyzer, a DMM, and the k_{SVR} filter components R_{SVR} and C_{SVR} . The RC measurement filter is used when the analyzer cannot accurately process the square wave output of the filter-free class-D APAs. DMM1 is used to measure V_S at the APA power pins. The generator injects a small sine-wave signal onto the power bus, and the audio analyzer measures this ac voltage at the APA power pin and at the output. Here the AP-II is configured for a crosstalk measurement, and sweeps the ac voltage at constant amplitude over the audio band, measuring and presenting a graph of the data points in dB.

Alternatives to the generator are to use a power source that has the capability to add an ac component to the output, or use a transformer to couple the ac signal onto the power bus. In any case, check the voltage that is applied to the APA power pins to be sure that the absolute maximum ratings of the APA are not exceeded at any point during the process.

The k_{SVR} filter circuit is shown in Figure 16. The dc power supply output impedance, R_S , is normally in the milli-ohms. The input impedance of the APA power pin, R_{APA} , is very high compared to this (in the hundreds or the thousands). The generator output signal sees R_{APA} and R_S in parallel and, because of the low value of R_S , this appears to be an ac ground. The resistor R_{SVR} is added to the circuit to increase the equivalent impedance of the power supply and is chosen to be approximately equal to the output impedance of the ac signal generator, R_{GEN} . A voltage divider, formed between R_{SVR} and R_{GEN} , provides a reasonable amplitude ac signal at the APA power pin. The large value of R_{SVR} is tolerable because the dc and ac supply currents are low. This is because the APA is idling and does not have any audio signal at the inputs, so the power dissipated in R_{SVR} is small.

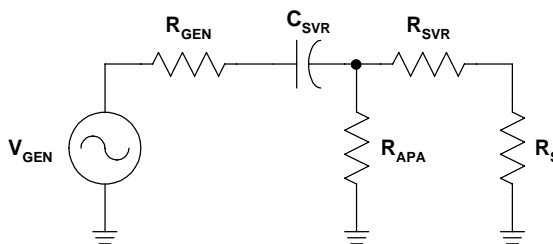

Figure 16. k_{SVR} Filter Circuit

The addition of C_{SVR} ac-couples the generator to the power bus and provides a high-pass filter for injecting the ac signal into the APA. The filter cutoff frequency, f_C , should be set below the lowest frequency of the audio band, f_{MIN} , which in this case is 20 Hz. Equation (13) provides the value for f_C , which is ~14 Hz.

$$f_C = \frac{f_{MIN}}{\sqrt{2}} \quad (13)$$

The equivalent resistance of Figure 20 is then calculated with Equation (14), where R_{APA} is the supply voltage divided by the quiescent current of the device (V_S/I_Q). The value for C_{SVR} is then calculated using Equation (15).

$$R_{EQ} = R_{GEN} + R_{APA} \parallel (R_{SVR} + R_S) \approx R_{GEN} + R_{SVR} \quad (14)$$

$$C_{SVR} = \frac{1}{2\pi \cdot f_C \cdot R_{EQ}} \quad (15)$$

The capacitor will most likely be electrolytic due to the value required. It will have some reactance that will vary with frequency range as shown by Equation (16). At 20 Hz the impedance will be quite high—approximately the value of R_{GEN} and R_{SVR} —and at 20 kHz the value will be in the milli-ohms.

$$X_{C_{SVR}} = \frac{1}{2\pi \cdot f_C \cdot C_{SVR}} \quad (16)$$

The actual values for the measurement circuit were $R_{GEN} = 20\Omega$, $R_S = 0$, $R_{APA} = 5V/6mA = 833\Omega$, $C_{SVR} = 330\mu F$, $R_{SVR} = 20\Omega$, $f_C = 12\text{ Hz}$. This yields a capacitive reactance of 24Ω at 20 Hz , and $24\text{ m}\Omega$ at 20 kHz . The value of the ac signal may need to be adjusted at low frequencies so that the desired voltage is applied to the APA power pin. The same is true for the dc voltage from the power supply, since I_Q will create a small voltage drop across R_{SVR} .

Those devices with BYPASS pins will have improved k_{SVR} as the capacitance on the pin is increased. Devices operated SE have lower k_{SVR} , particularly at the extreme low and high ranges of the audio frequency band. This is primarily due to the large output ac coupling capacitor, which dominates the frequency response both below and above the resonant frequency set by the equivalent series resistance (ESR) and equivalent series inductance (ESL) of the capacitor.

The k_{SVR} graphs are shown in Figure 17 for a 100-mV RMS input sine wave. Both of these devices are differential input and BTL output. The TPA731 is measured with the inputs floating, though newer devices are measured with the inputs ac-grounded. Figure 18 is a data sheet graph from the TPA711 that provides an example of how C_B impacts the k_{SVR} measurement of an SE output.

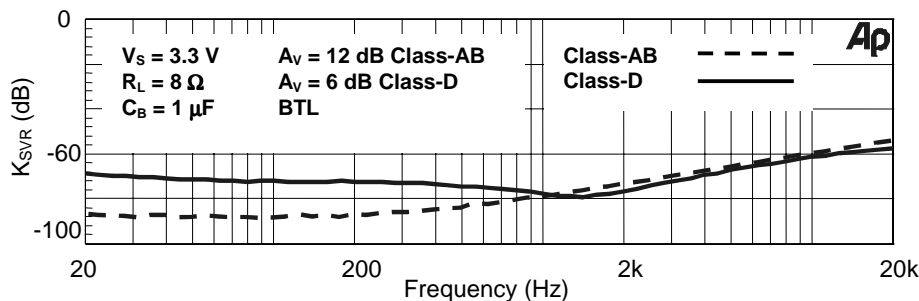

Figure 17. k_{SVR} of the TPA2001D1 and TPA731

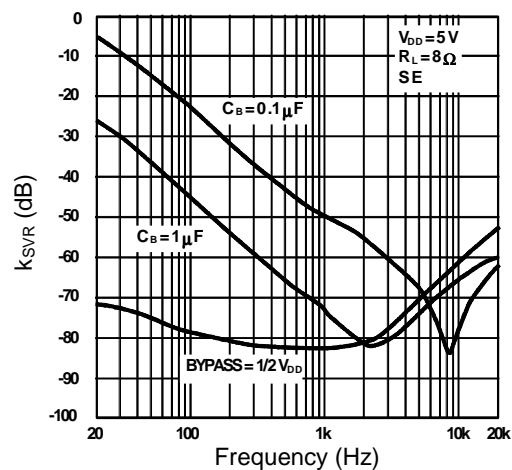

Figure 18. Impact of C_{BYPASS} on k_{SVR} for the TPA711 Class-AB APA

9 Power Measurements and Related Calculations

Several sets of data can be extracted from power measurements of a device. The power measurement process begins with the primary measurement of amplifier efficiency. The power that is dissipated by the amplifier is then calculated. This is useful for comparing the power supply requirements of different devices. The crest factor (CF) of the audio signal directly impacts the output power, and the effects are demonstrated from the dissipated power calculations.

9.1 Efficiency Measurements

Efficiency is the measure of the amount of power that is delivered to a load for a given input power provided by the supply. A class-AB APA acts like a variable resistor network between the power supply and the load, with the output transistors operating in the linear region. They dissipate quite a bit of power because of this mode of operation, and are therefore inefficient. The output stage in class-D APA acts as a switch that has a small resistance when operated in the saturation region, which provides a much higher efficiency.

A circuit for measuring the efficiency of a class-AB or class-D system is shown in Figure 19. The simplest setup results when the power supply voltage and current meters have the resolution required. When the supply current meter is not sufficient, R_1 is placed in the circuit. It should be a small value (0.1Ω) and able to handle the power dissipated. A voltage drop occurs across R_1 , so the supply voltage must be adjusted to set the desired V_S at the device power pin. The average voltage, V_1 , across R_1 provides the average supply current ($I_S = V_1/R_1$) that is used to calculate the average power provided by the supply.

The true-RMS DMMs and the audio analyzer provide an RMS value of both the voltage and the current, which, when multiplied together, provide the average power. When used, the power supply meters provide the average value of the supply voltage and current. The oscilloscope can measure the average or RMS values of the power supply and output voltage. Some oscilloscopes even have current probes that can be used to measure the current through a wire, in which case resistor R_1 is not needed.

The load measurement is different for class-AB and class-D APAs. Two elements are shown; one is the actual load, Z_L , and the other is resistor R_2 . The Class-AB load is a noninductive power resistor, $Z_L = R_L$, that must be capable of handling the maximum power output without a significant temperature increase, which will change the resistance and impact the measurement accuracy. This purely resistive load makes the output measurement easy since only the voltage across the load, V_{OUT} , is required in order to calculate the output power. The output is sinusoidal so all measurement devices should be ac-coupled to the load. There is some quiescent power dissipation in R_L , but this is negligible. Resistor R_2 is not required for class-AB efficiency measurements because the load is purely resistive.

The switching nature of the class-D makes the output measurement more challenging. First, a speaker is used as the load for the filter-free class-D because it has the inductance that helps provide the high class-D efficiency. A purely resistive load is not a true indicator of the operating environment of the filter-free class-D, and does not provide accurate efficiency numbers. Second, the output power must be calculated on the basis of current and voltage, not on the basis of impedance, because impedance varies with frequency. A small power resistor (R_2) is placed in series with the load and a DMM or analyzer is used to measure the RMS value of the load current ($I_{OUT} = V_2/R_2$). The RMS voltage across the entire load (speaker and resistor R_2) must be measured to provide the total power into the load.

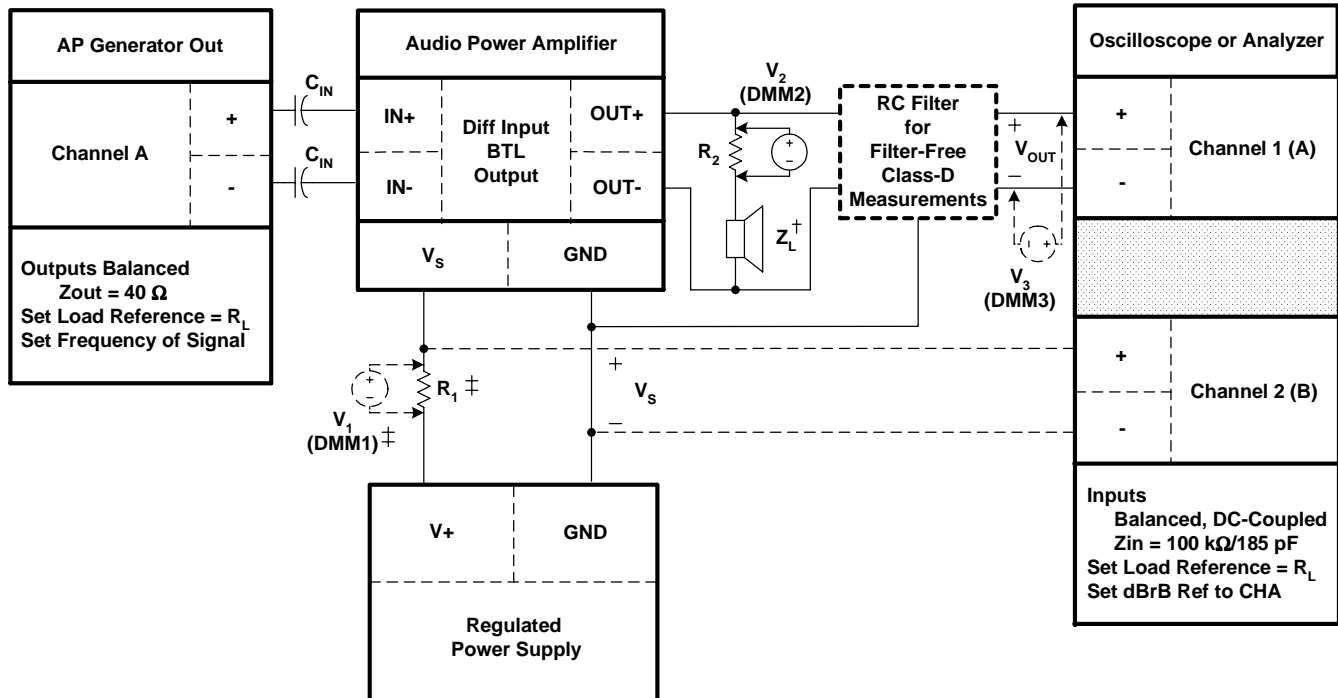

† Load Z_L is a speaker for class-D APAs and is a purely resistive load for class-AB APAs

‡ DMM1 and Channel 2 of the AP/oscilloscope (or a third DMM) are used to measure the average power supply current and voltage when power supply meters are not accurate. If not used, remove resistor R_1 .

Figure 19. Efficiency Measurement Circuit for Class-AB and Class-D BTL APAs

Equation (17) provides the efficiency of the class-AB APA, and Equation (18) provides the efficiency of the class-D APA. The input power of both equations, as stated previously, is just the average voltage applied to the power pins of the APA multiplied by the average value of the power supply current. Average value is used for the power supply measurements since the voltage and current have dc and ac components and are typically nonsinusoidal. The output power is also an average value that comes from the multiplication of two RMS terms.

$$\eta_{Class-AB} = \left(\frac{P_{OUT}}{P_S} \right) = \frac{\left(\frac{V_{L(RMS)}^2}{Z_L} \right)}{V_{S(ave)} \cdot I_{S(ave)}} \quad (17)$$

$$\eta_{\text{Class-D}} = \frac{P_{\text{OUT}}}{P_{\text{S}}} = \frac{V_{\text{O(RMS)}} \cdot I_{\text{O(RMS)}}}{V_{\text{S(ave)}} \cdot I_{\text{S(ave)}}} = \frac{V_{\text{O(RMS)}} \cdot \left(\frac{V_{\text{R}_2(\text{RMS})}}{R_2} \right)}{V_{\text{S(ave)}} \cdot I_{\text{S(ave)}}} \quad (18)$$

The RC measurement filter is used for making filter-free class-D output measurements when the analyzer or DMM cannot accurately process the switching output waveform. The filter resistance must be large enough to minimize current flow through the filter, while the capacitance must be sized to achieve the desired cutoff frequency, which should be just above the audio band. If the filter resistor is not large enough, the filter current must be accounted for in the efficiency equation. The recommended values of R_{FILT} and C_{FILT} are 1 kΩ and 5.6 nF, respectively. This provides a filter cutoff frequency of ~28 kHz. The filter is only required with class-D APAs and is discussed in more detail in Section 3.

The efficiency was measured with a 3.3-V supply and the results are shown in Table 3 and Figure 20 using the power supply meter and a Fluke 87III DMM measuring the voltage across the load. The DMM, AP analyzer, and TDS 754 oscilloscope measurements for the class-AB data were in close agreement. The class-D DMM and AP data were similar, but the oscilloscope measured 5-10% higher and is due to the averaging of the oscilloscope, which introduced a somewhat large margin of error, particularly at high power output. The DMM reading is more reliable since it filters out the high frequency harmonics of the switching waveform to provide a more stable low-frequency value.

Table 3. Efficiency Data for the TPA731 and TPA2001D1

Vs (Vave)	Is (mAave)	Ps (mWave)	Vout (mVrms)	Pout (mWave)	Eff (%)	Is (mAave)	Ps (mWave)	Vr (mVrms)	Vout (mVrms)	Pout (mWave)	Eff (%)
3.3	23	75.9	200	5.0	6.6	3	9.9	0.7	58	0.4	4.1
3.3	28	92.4	250	7.8	8.5	4	13.2	1.3	104	1.4	10.2
3.3	40	132.0	354	15.7	11.9	5	16.5	2.3	200	4.6	27.9
3.3	45	148.5	400	20.0	13.5	8	26.4	3.7	335	12.4	47.0
3.3	56	184.8	500	31.3	16.9	10	33.0	4.5	393	17.7	53.6
3.3	67	221.1	600	45.0	20.4	13	42.9	5.1	486	24.8	57.8
3.3	79	260.7	708	62.7	24.0	17	56.1	6.3	594	37.4	66.7
3.3	89	293.7	798	79.6	27.1	22	72.6	7.4	688	50.9	70.1
3.3	111	366.3	998	124.5	34.0	29	95.7	8.8	824	72.5	75.8
3.3	134	442.2	1197	179.1	40.5	39	128.7	10.3	973	100.2	77.9
3.3	156	514.8	1397	244.0	47.4	55	181.5	12.7	1179	149.7	82.5
3.3	158	521.4	1417	251.0	48.1	74	244.2	15.0	1370	205.5	84.2
3.3	-	-	-	-	-	107	353.1	18.3	1664	304.5	86.2
3.3	-	-	-	-	-	144	475.2	21.2	1932	409.6	86.2

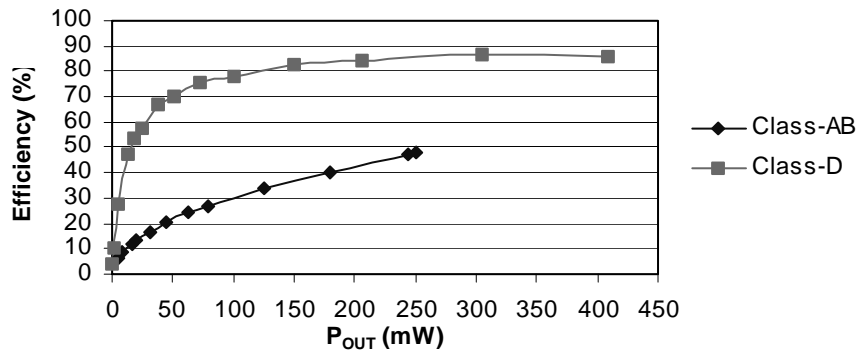

Figure 20. Efficiency Graphs of the TPA731 and TPA2001D1

9.2 Power Dissipated vs Power to the Load

The efficiency measurements provide the information required to calculate the amount of power dissipated, P_D , in the amplifier. P_D provides some insight into the supply currents that are required. P_D is calculated using Equation (19) and the measured values of supply and output power from Table 3. It is assumed that the power dissipated in the RC filter, used for the filter-free class-D APA measurements, is negligible.

$$P_D = P_S - P_{OUT} \quad (19)$$

Figure 21 shows graphs of P_D versus the P_{OUT} for the TPA731 class-AB and the TPA2001D1 filter-free class-D APAs, calculated from the efficiency data using Equation (19). The data was measured up to the maximum output power, which occurs just prior to clipping, and can easily be discerned from the THD vs Power graph. The designer can choose the percent distortion (level of clipping) that is acceptable for a system and test the device through that power level.

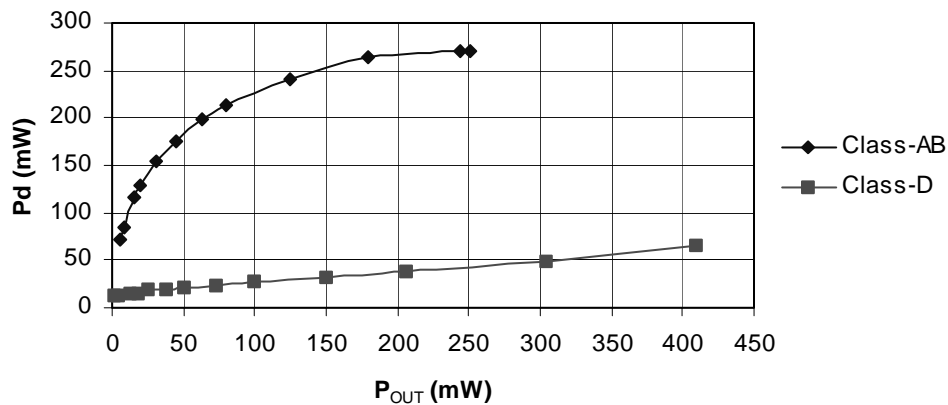

Figure 21. Graph of Power Dissipated vs Output Power

9.3 Crest Factor and Output Power

The crest factor (CF) is the ratio of the peak output to the average output. It is typically graphed in terms of output power and is expressed in dB. For example, the CF of a sine wave is 3 dB. Sine waves are used in the characterization of APA performance, but do not give a clear idea of what the performance will be with music. The CF of music may vary between 6 dB and 24 dB. The CF directly impacts the amount of heat dissipated in the device. The higher the CF, the lower the heat dissipated and the higher the ambient operating temperature can be. The P_D data of Section 9.2 can be used to determine the CF of the device.

Equation (20) may be used to calculate CF. Since a sine wave was used for the measurements, the CF is 3 dB, and the average output power ($P_{OUT(ave)}$) is known. The peak output power ($P_{OUT(pk)}$) is calculated by manipulating Equation (20) into Equation (21), where $P_{OUT(pk)}$ and $P_{OUT(ave)}$ are expressed in watts and CF is expressed in dB.

$$CF(dB) = 10 \log \left(\frac{P_{OUT(pk)}}{P_{OUT(ave)}} \right) \quad (20)$$

$$P_{OUT(ave)} = \frac{P_{OUT(pk)}}{10^{(CF/10)}} \quad (21)$$

For example, the maximum peak output power is 500 mW at for the TPA731. This is calculated using 250 mW as $P_{OUT(ave)}$ and a CF of 3 dB for the output sinusoid. The peak will not change throughout the calculations, as it is the maximum output power possible and is independent of the output waveform. The CF is then increased in 3 dB steps up to 18 dB and the corresponding $P_{OUT(ave)}$ is calculated for each step. The P_D in the device is measured for each value of $P_{OUT(ave)}$ using the efficiency measurement circuit.

The efficiency data and CF calculations can help the designer approximate the power that must be provided by the power supply. Table 4 shows the values of power for the supply, load, and what is dissipated in the amplifier for various CFs of the TPA731 class-AB APA and the TPA2001D1 class-D APA. The table was generated from measured data and calculations using Equations (19) through (21).

Figure 22 shows the graph of P_S and P_{OUT} versus CF from the data of Table 4. The graph allows easy comparison of the devices, and it is clear that the class-D APA provides more P_{OUT} with less power from the supply than the class-AB APA. The difference between P_S and P_{OUT} is the dissipated power, P_D .

Table 4. Power vs Crest Factor

P_{OUT} (mWave)	Crest Factor (dB)	P_S (mWave)	P_D (mWave)	P_{OUT} (mWave)	Crest Factor (dB)	P_S (mWave)	P_D (mWave)
251	3	521	270	410	3	475	66
125	6	366	242	206	6	244	39
63	9	261	198	100	9	129	28
31	12	185	154	51	12	73	22
16	15	132	116	25	15	43	18
8	18	92	85	12	18	14	148

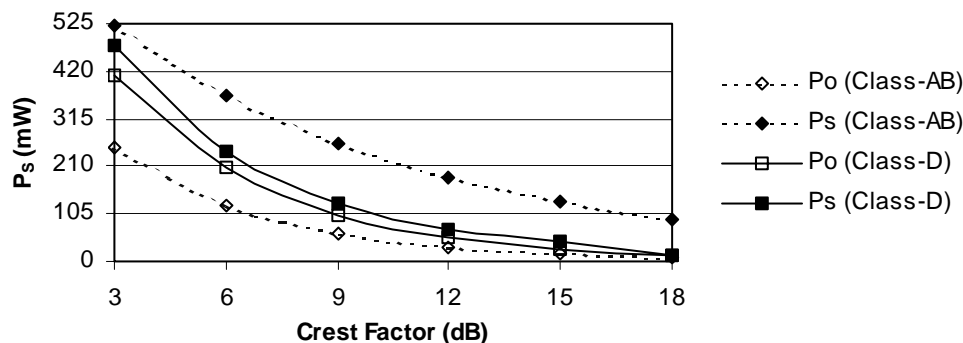

Figure 22. Supply and Output Power vs CF for the TPA731 and TPA2001D1

10 Measurement Pitfalls

This section contains a compilation of reminders to help avoid the various common mistakes, or pitfalls, that are made when measuring the APA devices. While they are not all-inclusive, it is the hope of the author that these may offer some insight that will save time and effort spent troubleshooting the circuit.

10.1 Effects of Improper Interfacing and Grounding

The primary concern is establishing a good connection to the APA. A good connection allows ground current to flow through a low-resistance return path and reduces noise injection into the system through ground loops. Grounding is a critical part of this connection, particularly at the APA inputs. THD+N levels were measured for various generator connections to a TPA2001D2 Class-D APA and are shown in Figure 23. The class-D has differential inputs and BTL outputs.

A balanced generator, used with differential inputs, has a maximum deviation of 0.02% THD+N between a grounded and floating source at low power, a difference that is negligible. The balanced generator provided the lowest value of distortion. It is comparable to an unbalanced generator that has a floating source as long as the positive (+) and negative (-) pins of the source are connected to the corresponding pins of the APA. The performance is degraded by 0.2% at lower power, and 0.01% at high power when the negative (-) pin is grounded at the APA. If the generator source is grounded, the performance decreases by over 0.2% across the power spectrum. A balanced source must therefore be used to remove the common-mode noise and minimize offsets from ground currents to provide the most accurate measurement.

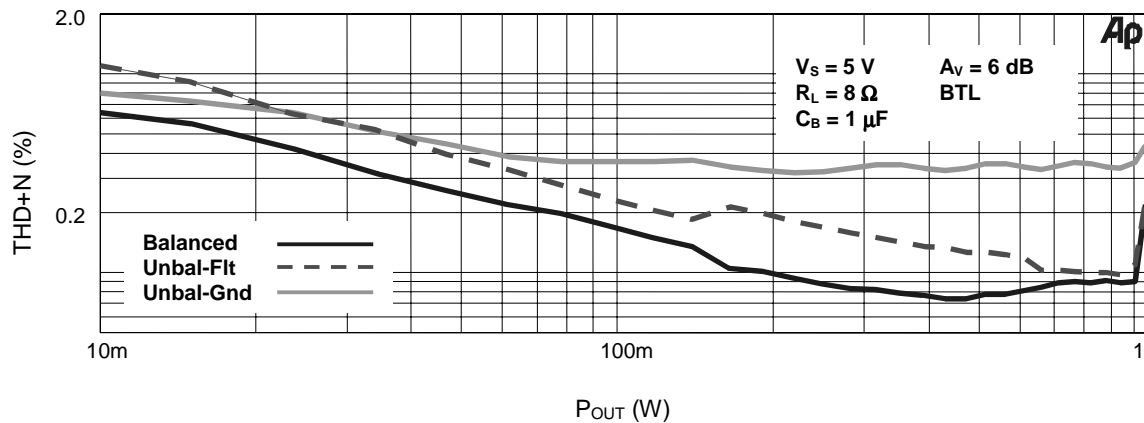

Figure 23. Effect of Generator Interface on APA Measurements, THD+N vs Power Shown

It may be necessary to tie the ground pin of the power supply or other system device to chassis ground to remove any 60-Hz component, called ac line or 60-Hz hum, from the signal path. This must be done carefully or ground loops will be formed that will increase distortion. References 4 and 6 have more information on grounding and ground loops.

To sum up the APA connections:

- Use a balanced source with differential inputs, unbalanced source with SE inputs.
- Ground the power supply chassis to remove any 60-Hz hum.
- The RC filter, used when measuring filter-free class-D APAs, should always be connected to ground at the APA to allow a path for return currents and to minimize the ground loop area.
- The lead and/or wire lengths of the filter components should be kept as short as possible.
- Power supply-to-APA and APA-to-load cables must be sized to avoid restricting the current flow.
- AC-ground all unused inputs during measurements.
- Check to be sure the source is warmed up and all measurement devices are calibrated.

10.2 THD+N Measurements

- The load resistance must be properly set in the analyzer software for correct output power.
- In the case of high distortion at lower power, check the ground connections, generator output configuration, and that the input and bypass capacitors are correct.

10.3 Noise Measurements

- Limit the measurement to the audio band, because the noise value is integrated over the specified frequency range.

10.4 Gain and Phase Measurements

- Reference the output voltage to the input voltage.
- Subtract 180 degrees from the phase when the phase shift is graphed greater than 180 degrees, which is often a characteristic of the analyzer.
- Adjust the analyzer bandpass filters to less than 10 Hz and greater than 30 kHz to remove their contribution to the phase shift in the audio band.

10.5 Crosstalk Measurements

- The output cables of both channels should be twisted pair wires to minimize ground loops.
- Reversed output connections result in a crosstalk that is measured in positive dB.
- Unused APA inputs should be ac-coupled to ground. Floating inputs decrease crosstalk.

10.6 Supply Rejection Measurements

- A 0.1 μ F decoupling capacitor is required for class-D operation during these measurements. All other capacitors should be removed. All decoupling capacitors should be removed for class-AB measurements.
- Be sure the output is being compared with the voltage at the power pins of the chip.
- A small resistor (20 Ω) must be in series with the power supply to develop the input voltage.
- As the value of bypass capacitance increases, k_{SVR} improves (decreases).

10.7 Efficiency Measurements

- Measure the supply voltage at the power pins of the chip.
- The filter-free class-D RC measurement filter should have a high resistance for R_{FILT} , with a value of 1 k Ω recommended. The current through the filter must be considered when the value is smaller than this.

11 References

1. www.audioprecision.com, Audio Precision Website
2. *Design Considerations for Class-D Audio Power Amplifiers* (SLOA031)
3. *Reducing and Eliminating the Class-D Output Filter* (SLOA023)
4. *Audio Measurement Handbook*, Metzler, Bob, Audio Precision, 1993.
5. *Introduction to Electroacoustics and Audio Amplifier Design*, Leach, W. Marshall Jr., Kendall/Hunt Publishing, 1999
6. *Noise Reduction Techniques in Electronic Systems*; Ott, Henry W., Wiley Interscience, 1976

IMPORTANT NOTICE

Texas Instruments Incorporated and its subsidiaries (TI) reserve the right to make corrections, modifications, enhancements, improvements, and other changes to its products and services at any time and to discontinue any product or service without notice. Customers should obtain the latest relevant information before placing orders and should verify that such information is current and complete. All products are sold subject to TI's terms and conditions of sale supplied at the time of order acknowledgment.

TI warrants performance of its hardware products to the specifications applicable at the time of sale in accordance with TI's standard warranty. Testing and other quality control techniques are used to the extent TI deems necessary to support this warranty. Except where mandated by government requirements, testing of all parameters of each product is not necessarily performed.

TI assumes no liability for applications assistance or customer product design. Customers are responsible for their products and applications using TI components. To minimize the risks associated with customer products and applications, customers should provide adequate design and operating safeguards.

TI does not warrant or represent that any license, either express or implied, is granted under any TI patent right, copyright, mask work right, or other TI intellectual property right relating to any combination, machine, or process in which TI products or services are used. Information published by TI regarding third-party products or services does not constitute a license from TI to use such products or services or a warranty or endorsement thereof. Use of such information may require a license from a third party under the patents or other intellectual property of the third party, or a license from TI under the patents or other intellectual property of TI.

Reproduction of information in TI data books or data sheets is permissible only if reproduction is without alteration and is accompanied by all associated warranties, conditions, limitations, and notices. Reproduction of this information with alteration is an unfair and deceptive business practice. TI is not responsible or liable for such altered documentation.

Resale of TI products or services with statements different from or beyond the parameters stated by TI for that product or service voids all express and any implied warranties for the associated TI product or service and is an unfair and deceptive business practice. TI is not responsible or liable for any such statements.

Mailing Address:

Texas Instruments
Post Office Box 655303
Dallas, Texas 75265