

CLASS D AMPLIFIERS ARE MUCH MORE EFFICIENT THAN OTHER CLASSICAL AMPLIFIERS, BUT THEIR HIGH EFFICIENCY COMES AT THE EXPENSE OF INCREASED NOISE AND DISTORTION. YOU CAN ASSESS THE FREQUENCY- AND TIME-DOMAIN CHARACTERISTICS OF A CLASS D AMPLIFIER, INCLUDING THE OUTPUT FILTER, USING ONLINE SIMULATIONS.

Class D audio-power amplifiers: Interactive simulations assess device and filter performance

UNLESS YOU'VE BEEN STUCK ON Survivor Island, you know growth in battery-operated electronic devices has exploded in the last few years. And, of course, one of the prime requirements for any battery-operated device is low power consumption. Every device in a signal chain must be as power efficient as possible to achieve a long battery life. This requirement applies to such ubiquitous components as amplifiers. For high efficiency, a Class D amplifier is the best type to use. A Class D type is much more efficient than other classical amplifiers but tends to achieve increased efficiency at the expense of increased noise and distortion.

With the advent of IC versions of Class D amplifiers, you can easily design an efficient amplifier suitable for battery-operated devices. The key to using an IC version of a Class D amplifier is designing an appropriate output filter. You can use any of the classic filters depending on your needs: Bessel for flat phase at the expense of stopband attenuation, Chebyshev for high-stopband attenuation at the expense of passband ripple, and Butterworth for no ripple. However, Butterworth is not a good choice for flat phase or for achieving the best stopband attenuation. The advent of online tools, such as WebSim, makes it easy to simulate various filter scenarios and examine frequency- and time-domain trade-offs. Just make sure you know what the performance objectives of the output filter need to be to optimize your design so you won't be voted off the island.

Traditionally, power amplifiers rely on a constantly biased output stage to produce low distortion. Low distortion results when you bias a transistor or MOSFET within its linear range so that signal excursions do not drive the output device near the saturation or cutoff condition. Power amplifiers must also be able to source and sink current so that the output can swing positive and negative with respect to ground.

Designers have developed several types of power-amplifier output stages, which have convenient labels, including Class A, Class B, and Class C. Class A, B, AB, and D are common in low-frequency audio designs and have some application in other areas, such as servo-motor drives and RF amplification. You see Class C, E, and F types only in RF

Figure 1

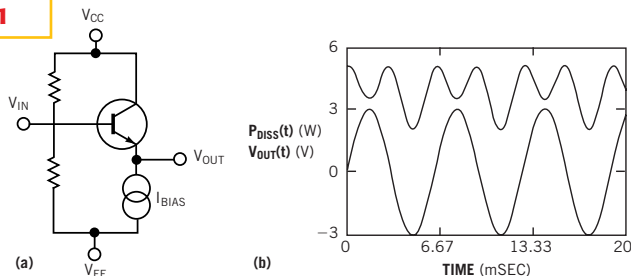

A Class A amplifier has one transistor in the output stage (a). Class A is the lowest distortion power amplifier but has poor efficiency (b).

designs. The lowest distortion power amplifier is the Class A (**Figure 1**). In this scheme, at least half of the output stage conducts the full-rated load current. However, one disadvantage of the Class A is its inefficiency; so much current flows in the output stage during low signal conditions or when these conditions are not occurring. In a Class B scheme, there are two series transistors in the output stage, and only one of them is turned on at a time (**Figure 2**). This type of output stage is much more efficient than Class A but gains its efficiency at the expense of distortion. The reason for the increased distortion is that as one transistor turns off, or becomes nonlinear, before the other transistor turns on, or becomes linear, the amplifier inevitably

has substantial nonlinearity and corresponding distortion for a period of time around the crossover point.

The definition of efficiency is:

$$\text{EFFICIENCY} = \frac{\text{POWER OUT}}{\text{POWER OUT} + \text{POWER DISSIPATED}}$$

Because the typical input impedance is fairly high in an audio application, internal amplifier losses, which stem primarily from output-stage losses, dominate efficiency. Class B power dissipation is for the same circuit conditions as Class A (**Figure 2b**). Class B turns on the upper transistor only for the positive half-cycle and the lower transistor only for the lower half-cycle, which makes Class B more efficient.

Figure 3 shows a Class AB output stage and the power dissipation for the same conditions as a Class A output stage. You can notice the slight increase in average power due to the bias current. The Class AB is almost as efficient as the Class B but is more linear because of the constant bias current.

CLASS D AMPLIFIERS IMPROVE EFFICIENCY

The development of Class D amplifiers represents an effort to improve amplifier efficiency. Similar in scheme to a switching regulator, a Class D amplifier pulse-width-modulates the audio-input signal with a higher frequency square wave so that audio-signal information becomes the variations in pulse width of the modulated signal (**Figure 4**). This

SIMULATING A CLASS D-AMPLIFIER CIRCUIT

You can see the operation of the CM8686 Class D power amplifier online at Transim's Web site by using WebSim (**Figure A**). Try the program at www.transim.com/champion/ by clicking "CM8686

amplifier with a two-pole filter operates at: 300 kHz." Select the efficiency test and click "Go." After the simulation completes, click the link toward the bottom of the page marked V_L1-V_L2.

You should see the same waveform as in **Figure B**, which is the unfiltered modulation waveform that shows the pulse modulation of the input sine wave. Change the input frequency and run the

simulation again to see how the modulation changes. Zoom in on the waveform by clicking and dragging it from the upper left side to the lower right side of the screen. Notice how the output is always switching and spends little time in the linear region, which is how Class D amplifiers gain their efficiency. Also click the voltage probe on the schematic marked V_OUT1. You should see a waveform similar to that in **Figure C** that shows the filtered output waveform, which is the amplified input without the switching artifacts.

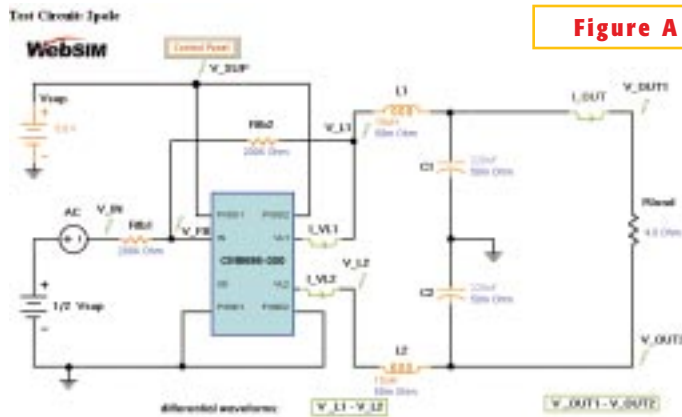

Figure A

Figure B

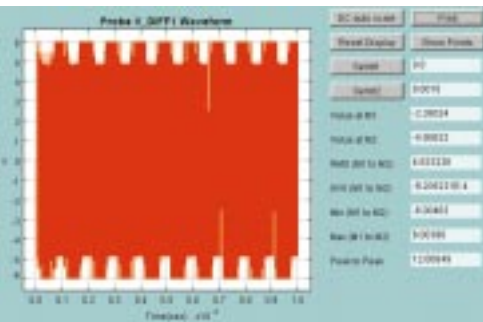
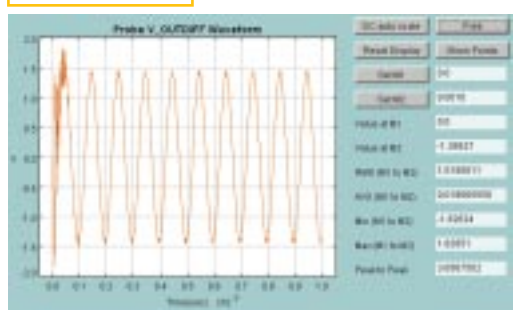
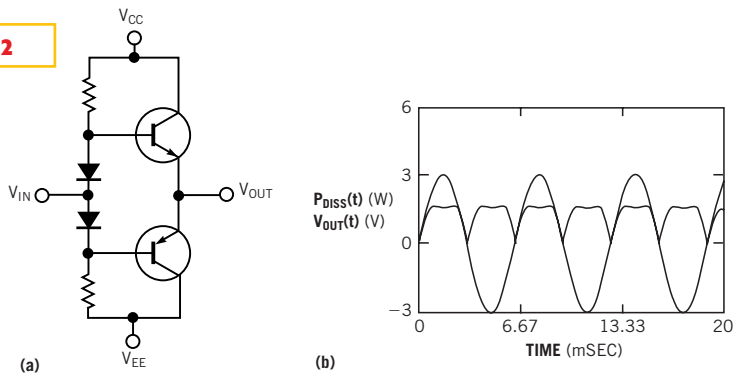

Figure C



Simulations of a Class D amplifier circuit (a) allow you to view the unfiltered modulation waveform at the amplifier's output (b) and the filtered output waveform (c).

Figure 2



In a Class B amplifier, only one of the two series transistors in the output stage is on at a time (a). This amplifier type is more efficient than a Class A (b) but has higher distortion.

modulation signal feeds a set of half-bridge switches, usually called H-bridges, and each H-bridge consists of two power MOSFETs. Unlike with Class A or B structures, you place the amplifier load, or the loudspeaker, across the legs of the bridge instead of from the output to ground. This configuration allows the amplifier to reproduce low-frequency signals as slow as 20 Hz without requiring bipolar power supplies or without introducing a dc offset in the output. The scheme then requires filtering the modulated output to remove high-frequency signals and recover the amplified audio-

input signal. Using this modulation approach, you can achieve efficiencies of 90% because the output stage is either cut off or saturated and doesn't spend any appreciable time in the inefficient linear region. Strictly speaking, H-bridges are not part of the definition of a Class D amplifier. However, H-bridges allow output to swing positive and negative while a unipolar supply powers the amplifier. This design doubles the output voltage and increases the output power by a factor of four compared with the output swing of a Class A or B amplifier with the same unipolar supply. For this

reason, Class D amplifiers almost always use H-bridges; they piggyback elegantly onto the switching topology of a Class D amplifier.

Figure 5a shows the schematic of a Class D amplifier IC (see sidebar "Simulating a Class D amplifier circuit"). The input drives one input of a comparator, and the other comparator input connects to a 300-kHz sawtooth generator. (This IC comes in both 300-kHz and more efficient 600-kHz versions). The output of the comparator connects to gate-drive circuitry that drives the complementary H-bridge output stage. The comparator pulse-width-modulates the ramp frequency with the audio signal. In another sense, the comparator is also sampling the audio signal and performing a 1-bit quantization. As a sampled-data system, the Class D amplifier produces aliasing of the input signal according to the Nyquist theorem. You can easily prevent aliasing by limiting the bandwidth of the audio signal going into the Class D amplifier to less than one-half of the switching frequency. In this case, the input bandwidth should be less than 150 kHz. Output filtering is necessary to remove the switching artifacts, which include the high-frequency-switching fundamental and

TRYING AN INTERACTIVE AMP + FILTER SIMULATION

You can try an interactive simulation of the CM8686 Class D amplifier IC with the three types of filters by clicking on the links below. You can run simulations of the Class D amplifier with the default filter configurations listed in Table A, or you can modify the circuit to try your own values.

TABLE A—FILTER-PERFORMANCE COMPARISON

Filter type	-3-dB frequency (kHz)	Attenuation at 150 kHz (dB)
Two-pole Butterworth	15	-40
Two-pole Chebyshev	15	-43 with 3-dB ripple
Two-pole Bessel	15	-40

Two-pole Butterworth:
www.transim.com/cgi-bin/init_webench.cgi?Device=CM8686&

Flavor=300&Circuit=2pole&web_id=champion&C1=3.75u&C2=3.75u&L1=30u&L2=30u&source=edn_demo

u&L1=19.3u&L2=19.3u&source=edn_demo

Two-pole Bessel:
www.transim.com/cgi-bin/init_webench.cgi?Device=CM8686&Flavor=300&Circuit=2pole&web_id=champion&C1=3.1u&C2=3.1u&L1=36.8u&L2=36.8u&source=edn_demo

Two-pole Chebyshev:
www.transim.com/cgi-bin/init_webench.cgi?Device=CM8686&Flavor=300&Circuit=2pole&web_id=champion&C1=8.2u&C2=8.2

When you start the analysis, you should see a plot similar to Figure A, which is the frequency-domain response of the CM8686 amplifier with the appropriate filter.

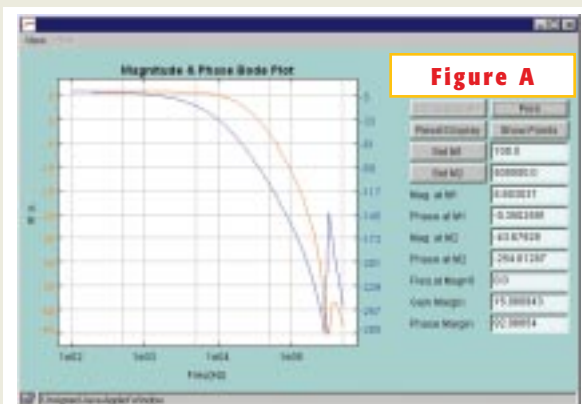

Figure A

An interactive simulation lets you view the performance of the CM8686 Class D amplifier IC with different filter types—in this case, a Chebyshev filter.

harmonics as well as intermodulation products of the switching and input-signal waveforms. **Figure 5b** shows the amplifier-output spectrum after passing through an 85-kHz lowpass filter, and you can see the intermodulation products around 300 kHz. More filtering is necessary to reduce undesirable harmonics. Typically, you filter a Class D audio amplifier to a much lower frequency than a switching frequency, such as 15 to 20 kHz.

As for distortion, this Class D amplifier IC has the same level of THD as an equivalent IC-type Class AB amplifier, typically about 0.5%. However, a Class D amplifier does not always have higher distortion than a Class AB amplifier. The quality of the filter, the amount of negative feedback (loop gain), and the quality of the board layout affect final THD numbers.

FILTERING HAS A LARGE IMPACT

Filter design has a big impact on the performance of the overall amplifier circuit. Besides impacting the amplifier design, the filter can also have a significant effect on production cost. A Class D amplifier may be more expensive than other amplifiers due to the cost of the required output-filter components. Because you place the filter, like the

Figure 3

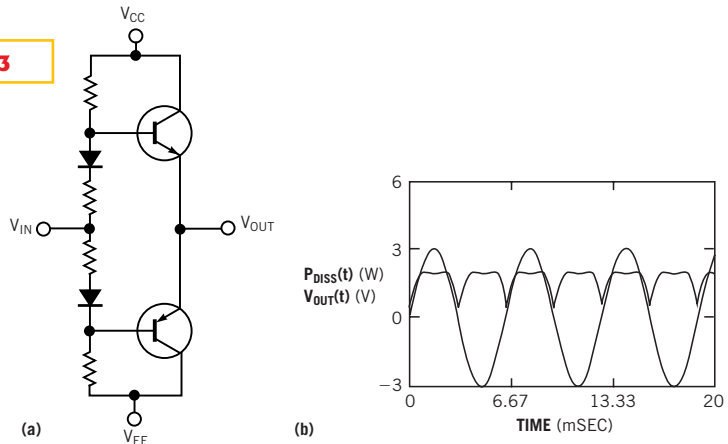

A Class AB amplifier (a) is almost as efficient as a Class B amplifier (b).

Figure 4

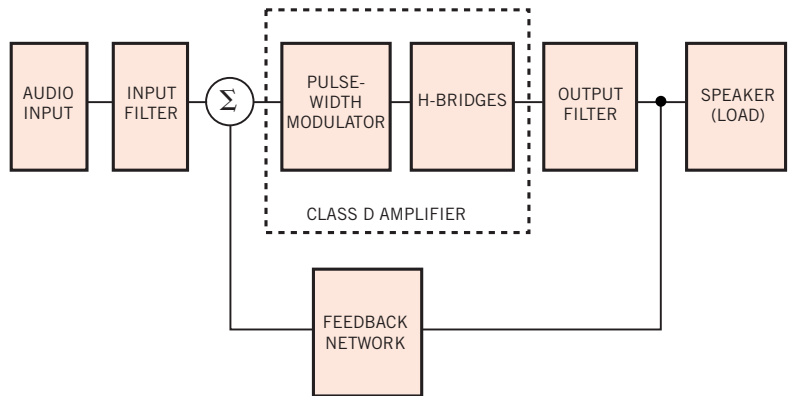

A Class D amplifier pulse-width-modulates the audio-input signal with a high-frequency square wave, and the modulated signal feeds a set of H-bridges. An external output filter is crucial to the amplifier scheme's performance.

Figure 5

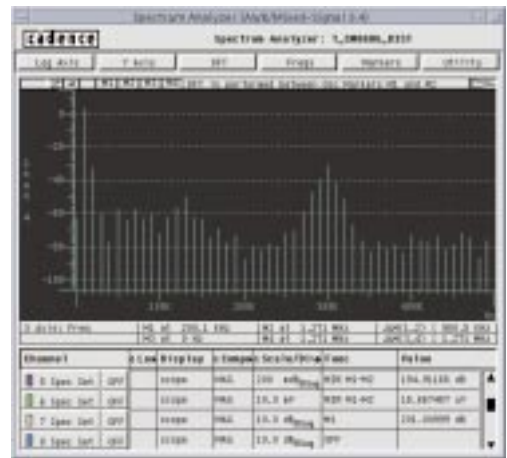
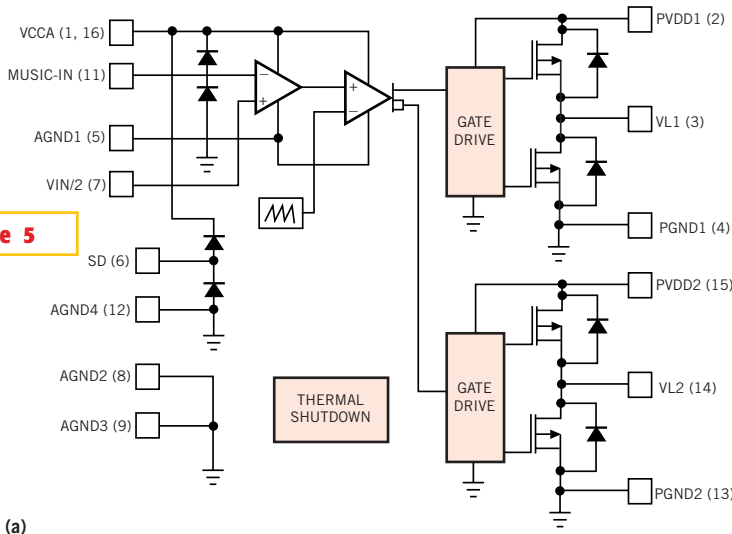

The CM8686 Class D amplifier IC uses comparators and a sawtooth generator to perform pulse-width-modulation (a). The output spectrum with an 85-kHz lowpass filter shows the intermodulation products around 300 kHz (b).

loudspeaker, across the two H-bridges, the resultant design requires a minimum of two inductors and two capacitors that need to carry the output current of the amplifier. On the other hand, because a Class D amplifier is more efficient, it requires less, if any, heat-sinking. However, you must resolve problems that EMI presents. Because Class D amplifiers are

switching high-frequency pulses, the resulting EMI-generating fast edges may require you to reduce the Class D amplifiers's conducted and radiated EMI. You can use ground and power planes as well as decoupling capacitors close to the power pins. You must keep the trace lengths short between the IC output pins and the output-filter inductors. The layout should keep the output traces and components away from the input circuitry.

The sources of efficiency and inefficiency in Class D amplifiers are substantially the same as for a switch-mode power supply. A Class D amplifier improves efficiency by switching at the highest possible frequency while keeping losses as low as possible. Losses stem from the $R_{DS(ON)}$ of the MOSFETs as well as switching losses due to the nonlinear gate capacitance of the MOSFETs. Switching losses increase as switching frequency increases, so there is a natural limit to the maximum switching frequency that is practical for a given level of MOSFET technology and performance. This limit is the point at which any efficiency that you gain by in-

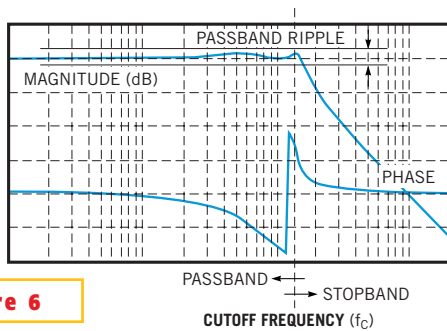

Figure 6

A Chebyshev filter has the best stopband characteristics but has only 3 dB of passband ripple.

creasing the switching frequency is balanced by an increase in losses.

The output filter is an integral part of the Class D amplifier (Figure 4). Because the filter typically has inductors and capacitors and is separate from the IC, you must add an external filter. To obtain the best signal fidelity, you need to carefully design the output filter to achieve the highest level of rejection of the switching modulation signal and artifacts while trying to maintain as much signal bandwidth as possible. For audio applications, you should also keep the passband amplitude and phase responses as flat as possible to keep fidelity as high as possible.

DESIGNING THE OUTPUT FILTER

Because the IC in Figure 5 primarily acts as an audio amplifier, you can design for a passband of 15 kHz and examine the performance of Butterworth, Chebyshev, and Bessel filters. Figure 6 shows the transfer-function response of the

Chebyshev filter, and Table A shows a summary of their performance (see sidebar “Trying an interactive amp+filter simulation”).

You can design filters for Class D amplifiers using a design program that handles passive filters, such as Filter Free (www.nuhertz.com/filter/), which is an excellent, free filter-design program. Usually, filter-design software assumes that you are designing a single-ended filter, but Class D amplifiers require a balanced filter. To convert the design, you have to design one-half of the filter using a load that is one-half of the actual load. Then, you use the inductor and capacitor values, L_1 and C_1 , that you calculated in the half-filter design on both legs of the balanced full filter. Thus, L_1 of the half-filter equals L_1 and L_2 of the full filter, and C_1 of the half-filter equals C_1 and C_2 of the full filter (Figure 7).

Which filter is the best one to use? The Chebyshev filter has the best stopband characteristics, but the high stopband attenuation comes at the expense of 3-dB passband ripple (the amplitude ripple below the cutoff frequency), which reduces signal fidelity. The Butterworth and Bessel filters do not suffer from passband ripple, and so these filters are a better choice. The Bessel topology has the advantage of more linear phase characteristics with approximately the same stopband attenuation (the attenuation of the amplitude above the filter cutoff frequency).

You should choose a filter based on your application. In a car stereo, for instance, you can trade off some stopband attenuation for better phase linearity by picking the Bessel filter. The filter-circuit topology changes only for the component values, not for each of the filter types. For the Bessel filter, the output inductor should equal $36.8 \mu\text{H}$, and the capacitor should equal $3.1 \mu\text{F}$.

You should choose a filter based on your application. In a car stereo, for instance, you can trade off some stopband attenuation for better phase linearity by picking the Bessel filter. The filter-circuit topology changes only for the component values, not for each of the filter types. For the Bessel filter, the output inductor should equal $36.8 \mu\text{H}$, and the capacitor should equal $3.1 \mu\text{F}$.

Figure 7

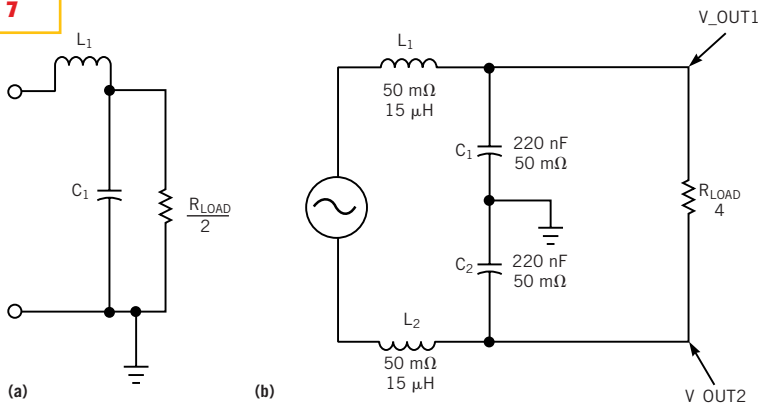

Most filter-design software assumes that you are designing a single-ended filter, so you have to design one-half of the filter (a) and convert the final values for the full filter (b).

AUTHOR'S BIOGRAPHY

Duncan McDonald is director of marketing at Transim Technology Corp (www.transim.com). He holds a BSEE from the University of California (Berkeley) and an MBA from the University of Santa Clara (CA). In his spare time, he enjoys building and flying high-power amateur rock-ets.