

Precise Tri-Wave Generation

National Semiconductor
Linear Brief 23
March 1986



Precise Tri-Wave Generation

INTRODUCTION

The simple Tri-wave generator has become an often used analog circuit. Tri-wave oscillators are more easily designed, require less circuitry, and are more easily stabilized than sine wave oscillators. Further, the highly linear output of today's Tri-wave generators make them useful in many "sweep" circuits and test equipment.

This article describes a triangle wave generator with an easily controlled peak-to-peak amplitude. The positive and negative peak amplitude is controllable to an accuracy of about $\pm 0.01V$ by a DC input. Also, the output frequency and symmetry are easily adjustable.

CIRCUIT DESCRIPTION

The Tri-wave oscillator consists of an integrator and two comparators—one comparator sets the positive peak and the other the negative peak of the Tri-wave. To understand the operation, assume that the output of the comparator is low ($-5V$). Then $-5.0V$ is applied through R1 to the input of the integrator. The LM118 will integrate positive until its output is equal to the positive reference on pin 9 of the LM119. Since the comparator outputs are low, D1 is reverse biased and the full output of the integrator is applied to the non-inverting input of comparator A. As the integrator output crosses the positive reference, comparator A switches "plus" and latches "plus" from positive feedback through D1 and R4. Now the polarity of the current to the integrator has changed and the integrator starts ramping negative. When the output reaches the negative reference voltage, comparator B swings negative. This forces the output of comparator A negative, also, and stops the positive feedback through D1 from holding the comparators' outputs positive. Once the positive feedback loop is broken, the outputs of the comparators stay low. With the comparators' outputs low, the integrator ramps positive again.

The frequency of operation is dependent upon R1, C1 and the reference voltages. Frequency is given by:

$$F = \frac{5.0V}{2R1 C1 (V_{REF+} - V_{REF-})}$$

The maximum frequency of operation is limited by the circuit delay to about 200 kHz. Also, the maximum difference in reference voltages is 5.0V.

APPLICATIONS

Regular or op amp testing is made easier with precise triangle waves. For example, IC voltage regulators are usually specified to operate over a certain input voltage range such as 7.0V to 25V. The Tri-wave generator can be set to deliver a 0.7V to 2.5V output. This output is then amplified by a factor of 10 by an op amp and used to sweep the regulator input over its operating range. With op amps, the generator can be used to sweep common mode voltages, power supply voltages, or even to test output swing. The output of the device can be displayed on an oscilloscope and performance monitored over the entire operating range.

Another application is a voltage controlled oscillator. Since the frequency depends on the input reference voltage, varying the reference varies the frequency. The useful VCO range is about 2 decades. The output is then taken from the comparators as the Tri-wave changes in amplitude.

Many sine wave oscillators use a non-linear network to convert triangle wave to sines. It is usually necessary to set triangle amplitude precisely for minimum distortion. If R1 is replaced by a pot, frequency can be varied over at least 10 to 1 range without affecting amplitude.

Symmetry is also easily adjustable. Current can be injected into the inverting input of the LM118 to change ramp time. The easiest way to achieve this is to connect a 50 k Ω resistor from the inverting input of the LM118 to the arm of a 1 k Ω pot. The ends of the pot are connected across the supplies. Current from the resistor either adds or subtracts from the current through R1, changing the ramp time.

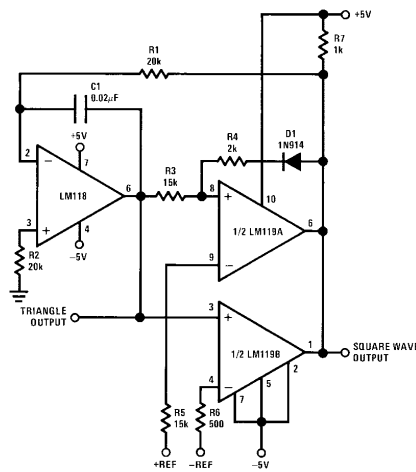

FIGURE 1. Precision Tri-Wave Generator

TL/H/8729-1

LB-23

LIFE SUPPORT POLICY

NATIONAL'S PRODUCTS ARE NOT AUTHORIZED FOR USE AS CRITICAL COMPONENTS IN LIFE SUPPORT DEVICES OR SYSTEMS WITHOUT THE EXPRESS WRITTEN APPROVAL OF THE PRESIDENT OF NATIONAL SEMICONDUCTOR CORPORATION. As used herein:

- 1. Life support devices or systems are devices or systems which, (a) are intended for surgical implant into the body, or (b) support or sustain life, and whose failure to perform, when properly used in accordance with instructions for use provided in the labeling, can be reasonably expected to result in a significant injury to the user.
- 2. A critical component is any component of a life support device or system whose failure to perform can be reasonably expected to cause the failure of the life support device or system, or to affect its safety or effectiveness.



National Semiconductor Corporation
 1111 West Bardin Road
 Arlington, TX 76017
 Tel: 1(800) 272-9959
 Fax: 1(800) 737-7018

National Semiconductor Europe
 Fax: (+49) 0-180-530 85 86
 Email: onjwge@tevm2.nsc.com
 Deutsch Tel: (+49) 0-180-530 85 85
 English Tel: (+49) 0-180-532 78 32
 Français Tel: (+49) 0-180-532 93 58
 Italiano Tel: (+49) 0-180-534 16 80

National Semiconductor Hong Kong Ltd.
 19th Floor, Straight Block,
 Ocean Centre, 5 Canton Rd.
 Tsimshatsui, Kowloon
 Hong Kong
 Tel: (852) 2737-1600
 Fax: (852) 2736-9960

National Semiconductor Japan Ltd.
 Tel: 81-043-299-2309
 Fax: 81-043-299-2408

National does not assume any responsibility for use of any circuitry described, no circuit patent licenses are implied and National reserves the right at any time without notice to change said circuitry and specifications.